



DETROIT™

DT12 PTO Installation Requirements

I. REAR PTO

Beginning in late 2016, the DT12 will be available with a rear-facing Power Take-Off (PTO). This PTO is a mechanical drive that attaches to the rear of the transmission and is used to transfer power produced by the engine to an auxiliary component.

NOTE: This rear facing PTO is approved for stationary & launch gear use only.

The interface is normally closed by a cover plate when not offered. However, when the DT12 PTO is ordered by the OEM/Dealer, the DT12 Transmission will arrive with the PTO hardware preinstalled from DETROIT™.

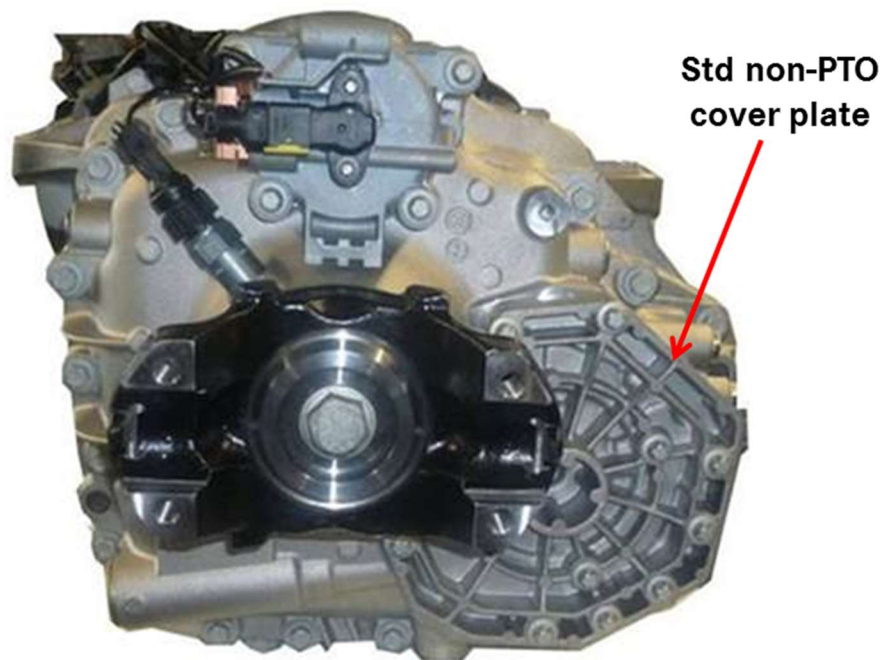

Figure 1: Rear of DT12 without PTO (cover plate only).

CONFIGURATIONS AVAILABLE

The 6 different SpecPro DT12 PTO configurations available from DETROIT™ are shown below:

1. *DT12 Hydrocar P89 Rear Mounted PTO for Hydraulic Pump (1:1.32 PTO Ratio)*

In this configuration, the cover plate shown in Figure 1 above is replaced by a PTO drive assembly as shown in Figures 2 & 3 below.



Figure 2: Rear DT12 PTO drive assembly (option 362-2HB) with cover plate.

With the access cover removed, the PTO drive assembly mounting flange offers SAE-B mounting for 2 or 4 bolt configurations and an SAE B-B 15 tooth spline as shown below:

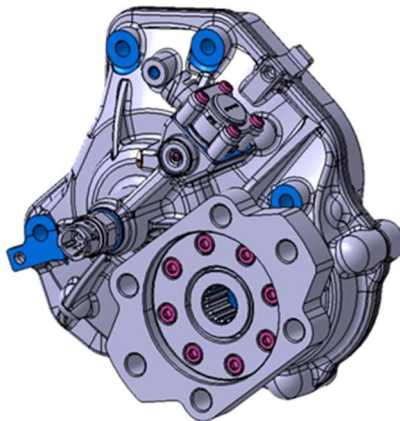

Figure 3: PTO drive assembly shown with SAE-B 2 or 4 bolt configuration.

The thread type for the 2 or 4 bolt pattern is M14 x 2.0 with a depth of 20mm. It is recommended to use a bolt length that allows for thread engagement of 1-1.5 times the diameter of the bolt used to connect the hydraulic pump. Unless otherwise specified by the pump manufacturer, use a bolt torque of 26-30 lb-ft (35-40 Nm) for the fasteners mounting the pump to the PTO drive assembly.

With this configuration:

- A transmission cooler will be added to DT12 configuration in SpecPro
- Some exhaust configurations are not compatible with DT12 PTO. Please consult with your local vehicle representative to obtain specifics.
- Harnesses and controls are included for PTO operation
- The pneumatic line is installed
- The PTO is ready for operation via dashboard mounted switch
- Consult Section 8.28 of the GHG14/17 DDEC13 A&I Manual (DDC-SVC-MAN-0127) for CPC parameterization

2. DT12 Hydrocar P89 Rear Mounted PTO for Driveshaft (1:1.32 PTO Ratio).

This configuration is for applications utilizing a driveshaft in place of a direct mounted hydraulic pump. From a transmission and PTO hardware perspective, it is identical to configuration #1 above. However, the difference in the options is that the prep for driveshaft allows for more clearance on the chassis around the PTO. When this option is ordered, the customer must order the following parts from the DTNA PDC:

- Spicer 1350/1410 or 1310 flange kit. The two available Spicer flange kit part numbers are:
 - a. Spicer 1350/1410 Flange: A9472600317 (See Figure 6 for the dimensions)
 - b. Spicer 1310 Flange: A9472600417 (See Figure 7 for the dimensions)

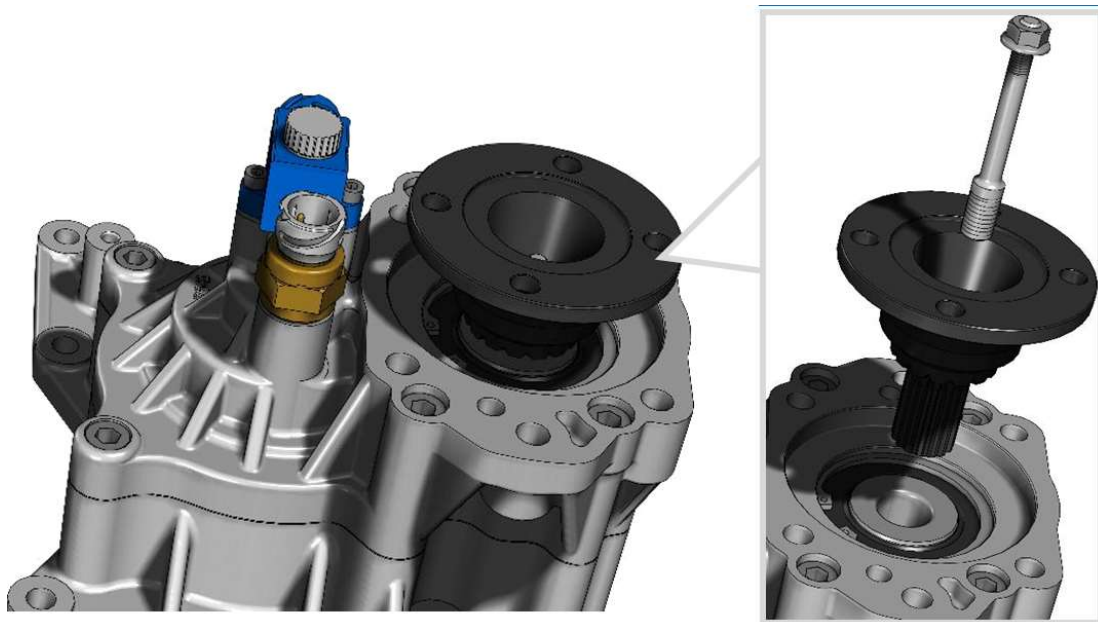

Figure 4: Rear DT12 PTO driveshaft assembly with driveshaft mount.

An example of a successfully installed Spicer flange per option #2 can be seen in the following figure.



Figure 5: Installation of configuration #2 as seen from the rear of the vehicle

With this configuration:

- A transmission cooler will be added to DT12 configuration in SpecPro
- Some exhaust configurations are not compatible with DT12 PTO. Please consult with your local vehicle representative to obtain specifics.
- Harnesses and controls are included for PTO operation
- The pneumatic line is installed
- The PTO is ready for operation via dashboard mounted switch
- Consult Section 8.28 of the GHG14/17 DDEC13 A&I Manual (DDC-SVC-MAN-0127) for CPC parameterization

To correctly install a Spicer flange kit onto the DT12 Rear PTO:

1. Remove cover plate on DT12 Rear PTO housing
2. Insert the stud "1" into the center of the splined PTO drive on the DT12
3. Tighten stud to a torque of 11 ± 1.5 lb-ft (15 ± 2 Nm)
4. Install the spacer "3" on the back of the flange "4"
5. Apply grease "OKS 200" on the profile spline of the flange "4"
6. Install flange "4" into the PTO gear, then install nut "5" and torque to 26 ± 3.5 lb-ft (35 ± 5 Nm)

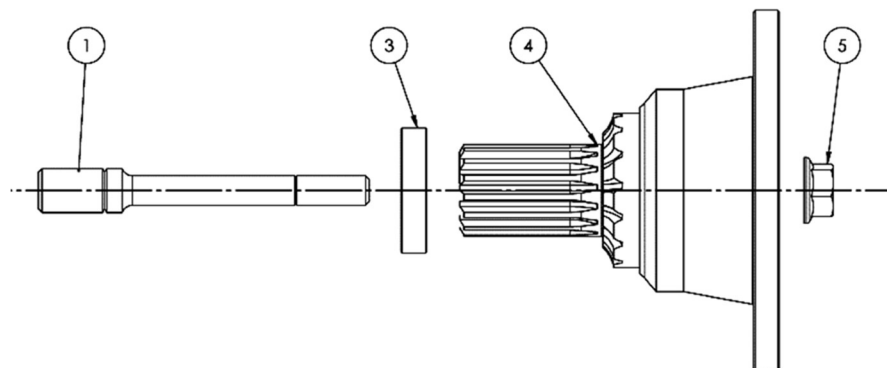

Figure 6: Installation of the 1350/1410 and 1310 series flange adapter kits to the DT12 Rear PTO.

With this configuration the PTO drive shaft angle must be in the range of 1° to 6°. Bolts and nuts for attaching the driveshaft to this adapter flange are not included in either of the Spicer kits. Use standard torque values to attach bolts to adapter flange based on hardware material and grade.

3. *DT12 Hydrocar P89 Rear Mounted PTO with Prep for Hydraulic Pump (1:1 PTO Ratio).*

This configuration is the same as configuration #1 above, except that the PTO Drive ratio here is 1:1.

With configuration #3:

- The Rear PTO drive assembly mounting flange offers SAE-B mounting for 2 or 4 bolt configurations and an SAE B-B 15 tooth spline as shown in Figure 3 above.
- The thread type for the 2 or 4 bolt pattern is M14 x 2.0 with a depth of 20mm. It is recommended to use a bolt length that allows for thread engagement of 1-1.5 times the diameter of the bolt used to connect the hydraulic pump. Unless otherwise specified by the pump manufacturer, use a bolt torque of 26-30 lb-ft (35-40 Nm) for the fasteners mounting the pump to the PTO drive assembly.
- A transmission cooler will be added to DT12 configuration in SpecPro.
- Some exhaust configurations are not compatible with DT12 PTO. Please consult with your local vehicle representative to obtain specifics.
- Harnesses and controls are included for PTO operation.
- The pneumatic line is installed.
- The PTO is ready for operation via dashboard mounted switch.
- Consult Section 8.28 of the GHG14/17 DDEC13 A&I Manual (DDC-SVC-MAN-0127) for CPC parameterization.

4. *DT12 Hydrocar P89 Rear Mounted PTO for Driveshaft (1:1 PTO Ratio).*

This configuration is for applications utilizing a driveshaft in place of a direct mounted hydraulic pump. From a hardware perspective, it is identical to configuration #2 above, except that the PTO Drive ratio here is 1:1 instead of the 1:1.32 of configuration #2 above.

With configuration #4, the customer must order the following parts from the DTNA PDC:

- Spicer 1350/1410 or 1310 flange kit. See Figure 4-5 above for installation pics of the driveshaft adapter. The two available Spicer flange kit part numbers are:
 - Spicer 1350/1410 Flange: A9472600317 (See Figure 6 for the dimensions)
 - Spicer 1310 Flange: A9472600417 (See Figure 7 for the dimensions)
- A transmission cooler will be added to DT12 configuration in SpecPro
- Some exhaust configurations are not compatible with DT12 Rear PTO. Please consult with your local vehicle representative to obtain specifics.
- Harnesses and controls are included for Rear PTO operation
- The pneumatic line is installed
- The PTO is ready for operation via dashboard mounted switch
- Consult Section 8.28 of the GHG14/17 DDEC13 A&I Manual (DDC-SVC-MAN-0127) for CPC parameterization

To correctly install a Spicer flange kit onto the DT12 Rear PTO:

1. Remove cover plate on DT12 Rear PTO housing
2. Insert the stud "1" into the center of the splined PTO drive on the DT12
3. Tighten stud to a torque of 11 ± 1.5 lb-ft (15 ± 2 Nm)
4. Install the spacer "3" on the back of the flange "4"
5. Apply grease "OKS 200" on the profile spline of the flange "4"
6. Install flange "4" into the PTO gear, then install nut "5" and torque to 26 ± 3.5 lb-ft (35 ± 5 Nm)

With this configuration the PTO drive shaft angle must be in the range of 1° to 6°. Bolts and nuts for attaching the driveshaft to this adapter flange are not included in either of the Spicer kits. Use standard torque values to attach bolts to adapter flange based on hardware material and grade.

See Figure 6 above for the installation of the 1350/1410 and 1310 series flange adapter kits to the DT12 Rear PTO.

5. *PTO Prep Kit for DT12 Hydrocar P89 Rear Mounted PTO Prep for Driveshaft.*

This is the same as configuration # 2 and configuration #4 above, except the Rear PTO drive assembly is NOT installed on the DT12 transmission as delivered. When this configuration is ordered, the customer must order the following parts from the DTNA PDC:

- DT12 PTO drive assembly
 - Assembly p/n A9472600705 for the 1:1 PTO ratio
 - Assembly p/n A9472600605 for the 1:1.32 PTO ratio
- Transmission Top 5 shim kit, p/n A3892625056
- Shaft kit for attaching the rear-mount DT12 PTO drive assembly
 - P/N A9472602492 for A-box transmissions
 - P/N A9472602192 for B-box transmissions
- Spicer 1350/1410 or 1310 flange kit.

See DTNA PTO installation guideline document for installation instructions and torque specifications for installing the DT12 Rear PTO drive housing.

With this configuration:

- A transmission cooler will be added to DT12 configuration in SpecPro
- Some exhaust configurations are not compatible with DT12 PTO. Please consult with your local vehicle representative to obtain specifics.
- Harnesses and controls are included for PTO which is installed at a later time
- The pneumatic airline is NOT installed and would need to be added at the time of PTO install
- Consult Section 8.28 of the GHG14/17 DDEC13 A&I Manual (DDC-SVC-MAN-0127) for CPC parameterization

6. *PTO Prep Kit for DT12 Hydrocar P89 Rear Mounted PTO Prep for Hydraulic Pump.*

This is the same as configuration # 1 and configuration #3 above, except the Rear PTO drive assembly is NOT installed on the DT12 transmission as delivered. When this configuration is ordered, the customer must order the following parts from the DTNA PDC:

- DT12 Rear PTO drive assembly
 - Assembly p/n A9472600705 for the 1:1 PTO ratio
 - Assembly p/n A9472600605 for the 1:1.32 PTO ratio
- Transmission Top 5 shim kit, p/n A3892625056
- Shaft kit for attaching the rear-mount DT12 PTO drive
 - P/N A9472602492 for A-box transmissions
 - P/N A9472602192 for B-box transmissions

With this configuration:

- A transmission cooler will be added to DT12 configuration in SpecPro
- Some exhaust configurations are not compatible with DT12 Rear PTO. Please consult with your local vehicle representative to obtain specifics.
- Harnesses and controls are included for the Rear PTO which is installed at a later time
- The pneumatic airline is NOT installed and would need to be added at the time of PTO install.
- Consult Section 8.28 of the GHG14/17 DDEC13 A&I Manual (DDC-SVC-MAN-0127) for CPC parameterization

See DTNA PTO installation guideline document for installation instructions and torque specifications for installing the DT12 Rear PTO drive assembly as well as the pneumatic line referenced above.

The dimensions for the Spicer 1350/1410 and 1310 series PTO flanges are listed in the figures below.

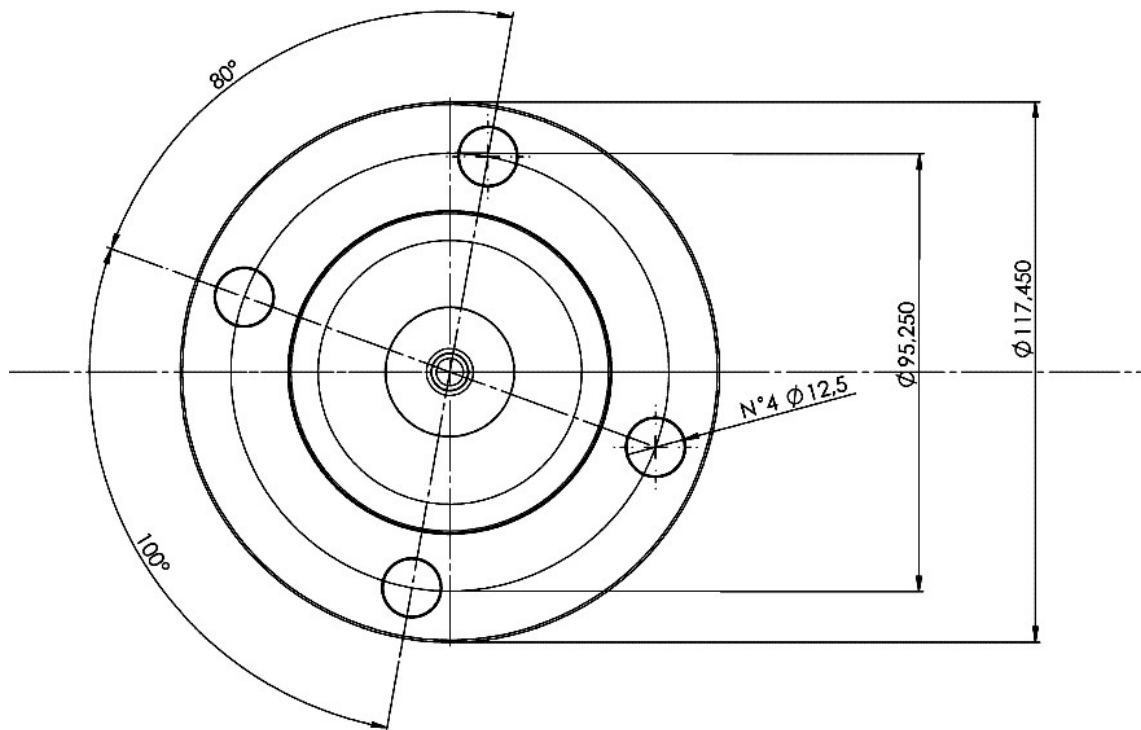

Figure 7: Spicer 1350/1410 series adapter flange, p/n A9472600317, for Rear PTO.

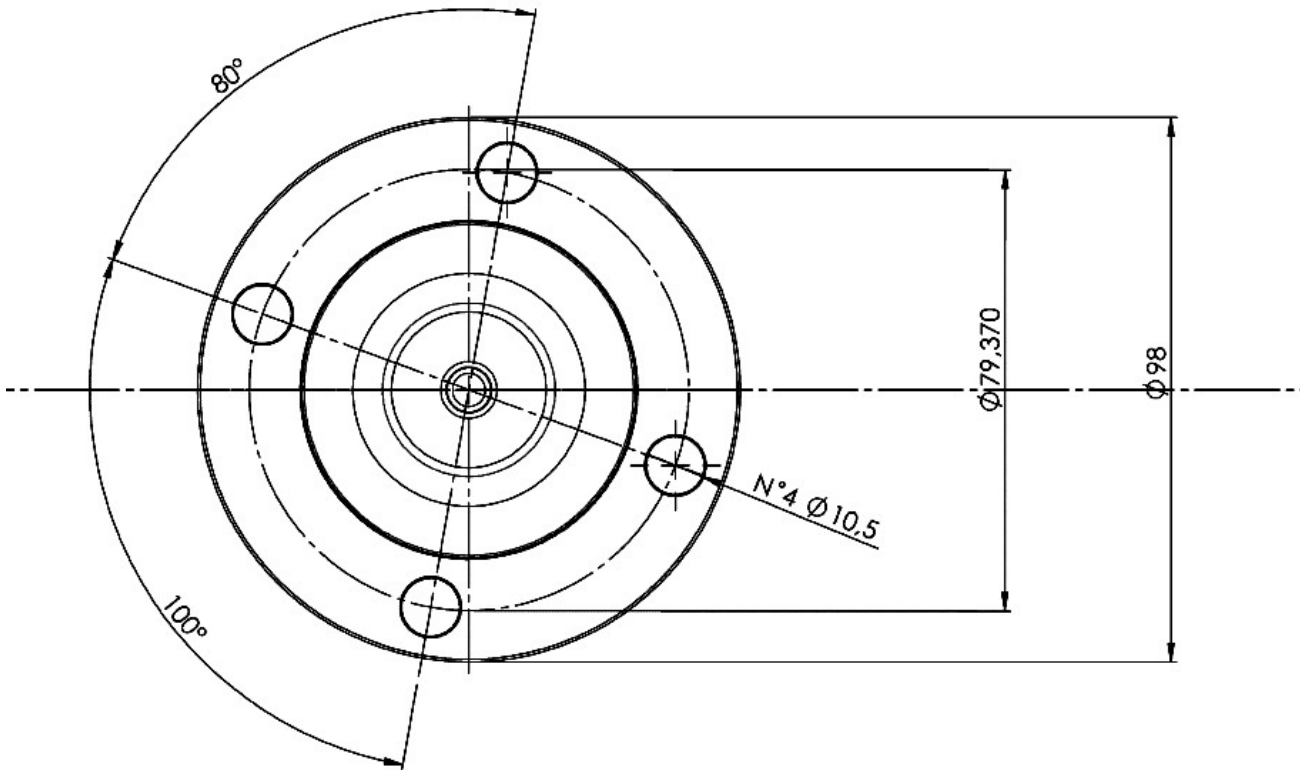

Figure 8: Spicer 1310 adapter flange, p/n A9472600417, for Rear PTO.

REAR PTO TECHNICAL INFORMATION / INSTALLATION REQUIREMENTS

- Engine speed: 850 - 2080 rpm
- Vehicle speed during Rear PTO Operation: 1) 0 mph (vehicle is stationary)
2) Launch gear only operation
- Rear PTO output speed:
 - 1 : 1.32 PTO Ratio:

Direct Drive Split Low	900 - 2250 rpm
Direct Drive Split High	1150 - 2850 rpm
Over Drive Split Low	1150 - 2850 rpm
Over Drive Split High	1500 - 3700 rpm
 - 1 : 1 PTO Ratio:

Direct Drive Split Low	650 - 1600 rpm
Direct Drive Split High	850 - 2100 rpm
Over Drive Split Low	850 - 2100 rpm
Over Drive Split High	1100 - 2700 rpm
- Max Rear PTO output torque: 295 lb·ft (400 N·m)
384 lb ft (520 N·m) max. shock load

- PTO drive shaft angle 1° to 6°
- Interface (mount) 2 or 4 bolt SAE B pad mount
- Interface (shaft) SAE BB 15 tooth spline drive
- Interface (flange drive) Spicer 1350/1410 and Spicer 1310 flange drives
- Rear PTO rotation Counterclockwise (CCW) looking from rear of DT12
(Requires CW input pump)



Figure 9: Rear PTO rotation direction

- Transmission Oil temperature range: average 80°C (176°F)
max. 100°C (212°F)
- Ambient operating conditions -40°C (-40°F) to 45°C (113°F)
- Transmission Rear PTO variant availability All DT12 variants (oil cooler is required)
- The maximum bending moment 29.5 lb-ft (40 Nm)

LAUNCH GEAR ONLY REAR PTO OPERATION

NOTE: Launch gear PTO operation requires Citrine CEAA+ level software or newer. Older levels of software are NOT capable of utilizing this vehicle operation mode.

This configuration is only allowed when launching from a complete stop, utilizing the vehicle's launch gear.

To operate in this manner:

- Make sure the transmission is in neutral,
- Engage the Rear PTO,
- Shift transmission into gear with foot on the service brake,
- Release brake to get the vehicle moving.
- To disengage the PTO, unload the PTO/system first.
- Then disengage the PTO while moving or stopped.

NOTE: The transmission may not shift gears while the vehicle is being driven with the Rear PTO engaged. Manually shifting gears with the Rear PTO engaged is also not allowed.

NOTES: 1) The maximum bending moment of the Rear PTO to the transmission mounting surface must be calculated including the length of unsupported hydraulic hoses, and the weight of the fittings and hydraulic fluid. Support brackets are NOT allowed!
2) The maximum bending moment allowed between the Rear PTO and the DT12 transmission is 29.5 lb-ft (40 N-m).

Unless specific information is available on the pump mounting hardware, please use the following formulas and weights provided below.

- Hydraulic hose fittings: 1.18 lbs each
- Weight of hydraulic fluid:

$$= (\# \text{ of hydraulic hoses}) * (0.0361) * [(3.142) * ((\text{Hose ID}/2)^2) * (\text{Length of hoses to first clipping point})]$$
- Weight of hydraulic hose

$$= (\# \text{ of hydraulic hoses}) * (\text{Hose weight}/\text{ft}) * (\text{length in feet of hoses to 1}^{\text{st}} \text{ clipping point})$$
- Hydraulic hose weight estimation chart:

Hydraulic Hose Chart Estimation	
Hose I.D.	lbs/ft
1/4	0.16
3/8	0.23
1/2	0.35
5/8	0.44
3/4	0.58
1	0.79
1 -1/4	1.5

Table 1: Typical hydraulic hose weight estimation chart.

$$\text{Max Bending Moment} = M_{\text{pump}} + M_{\text{ftgs}} + M_{\text{fluid}} + M_{\text{hoses}}$$

where

$$M_{\text{pump}} = \text{Bending Moment of the hydraulic pump (lb-ft)}$$

$$= (\text{weight of pump in lbs}) * [(\text{distance from pump center of gravity to PTO mounting surface in inches})/12]$$

If center of gravity is not known, assume this is at 1/2 the total length of the pump

$$M_{\text{ftgs}} = \text{Bending moment of the hydraulic line fittings (lb-ft)}$$

$$= (\# \text{ of fittings}) * (\text{weight of fittings in lbs}) * [(\text{distance of fittings from pump mounting surface in inches}) / 12]$$

$$M_{\text{fluid}} = \text{Bending moment due to the hydraulic fluid (lb-ft)}$$

$$= (\# \text{ of hydraulic hoses}) * (\text{weight of fluid}) * [(1/2 * \text{length of hoses until first clipping point}) + (\text{distance of pump center of gravity to PTO mounting surface})]$$

$$M_{\text{hoses}} = \text{Bending moment due to the hydraulic hoses (lb-ft)}$$

$$= (\# \text{ of hydraulic hoses}) * (\text{weight of hoses in lbs}) * [(1/2 * \text{length of hoses until first clipping point}) + (\text{distance of pump center of gravity to PTO mounting surface})] / 12$$

If the calculated Bending Moment exceeds the 29.5 lb-ft limit, try shortening the length of the hydraulic hoses to the first clipping/support point.

PTO OUTPUT SPEED CALCULATION

Since the DT12 Rear PTO is driven by the countershaft inside the transmission, there are two effective gear ratios possible, low neutral or high neutral. The low neutral and high neutral are referred to as “split low” and “split high” respectively.

There is a data code module in SpecPro that allows for operation to be set to either “split low” or “split high”. This functionality allows the operator to engage the PTO at the desired gear ratio for proper operation. The PTO ratio, once chosen, will be active at the time of the PTO engagement, Split Low/High cannot be changed by the driver in the cab.

The default data code for the DT12 Rear PTO is “split low” upon PTO activation.

The available options in SpecPro are:

- 85P-001: PTO LOW NEUTRAL
- 85P-002: PTO HIGH NEUTRAL
- 85P-998: NO PTO NEUTRAL GEAR SELECTION

The default operation for the DT12 Rear PTO is “split low” upon PTO activation. However, parameterization in the CPC allows for operation to be set to either “split low” or “split high”. See the GHG14/17 DDEC13 Electronic Controls Application and Installation Manual (DDC-SVC-MAN-0127) Section 8.28 Throttle Control/Governors via www.DTNAconnect.com for specific parameter programming information.

Rear PTO speed can be calculated by using the PTO output speed summary table below (the released of the 1:1.83 ratio is TBD at this time):

DT12 Variant	" Split"	PTO Ratio (1 : 1)		PTO Ratio (1 : 1.32)	
		Engine : PTO	Percent	Engine : PTO	Percent
DT12-DHL (DB)	Split Low	1 : 0.78	78%	1 : 1.06	106%
	Split High	1 : 1	100%	1 : 1.36	136%
DT12-OHL (OB)	Split Low	1 : 1	100%	1 : 1.36	136%
	Split High	1 : 1.28	128%	1 : 1.74	174%
DT12-DH (DA)	Split Low	1 : 0.78	78%	1 : 1.06	106%
	Split High	1 : 1	100%	1 : 1.36	136%
DT12-OH (OA)	Split Low	1 : 1	100%	1 : 1.36	136%
	Split High	1 : 1.29	129%	1 : 1.76	176%
DT12-DHE/DV (DC)	Split Low	1 : 0.71	71%	1 : 0.97	97%
	Split High	1 : 0.92	92%	1 : 1.25	125%
DT12-OHE/OV (OC)	Split Low	1 : 0.92	92%	1 : 1.25	125%
	Split High	1 : 1.18	118%	1 : 1.61	161%
DT12-OVX (OD)	Split Low	1 : 0.94	94%	1 : 1.28	128%
	Split High	1 : 1.21	121%	1 : 1.65	165%
NOTE: Ratios Greater than 1:1, or over 100% → PTO spins faster than engine					

Table 2: Rear PTO output speed summary table.

For example, the Rear PTO speed with a DT12-DA (DH) Split Low with the 1:1 PTO Ratio would be:

$$(\text{Engine RPM}) \times (\text{Engine:PTO Ratio}) = 850 \text{ rpm} \times 0.78 = 663 \text{ rpm}$$

Similarly, the Rear PTO speed with a DT12-OC (OHE & OV) Split High with the 1:1.32 PTO Ratio would be

$$(\text{Engine RPM}) \times (\text{Engine:PTO Ratio}) = 850 \text{ rpm} \times 1.61 = 1369 \text{ rpm}$$

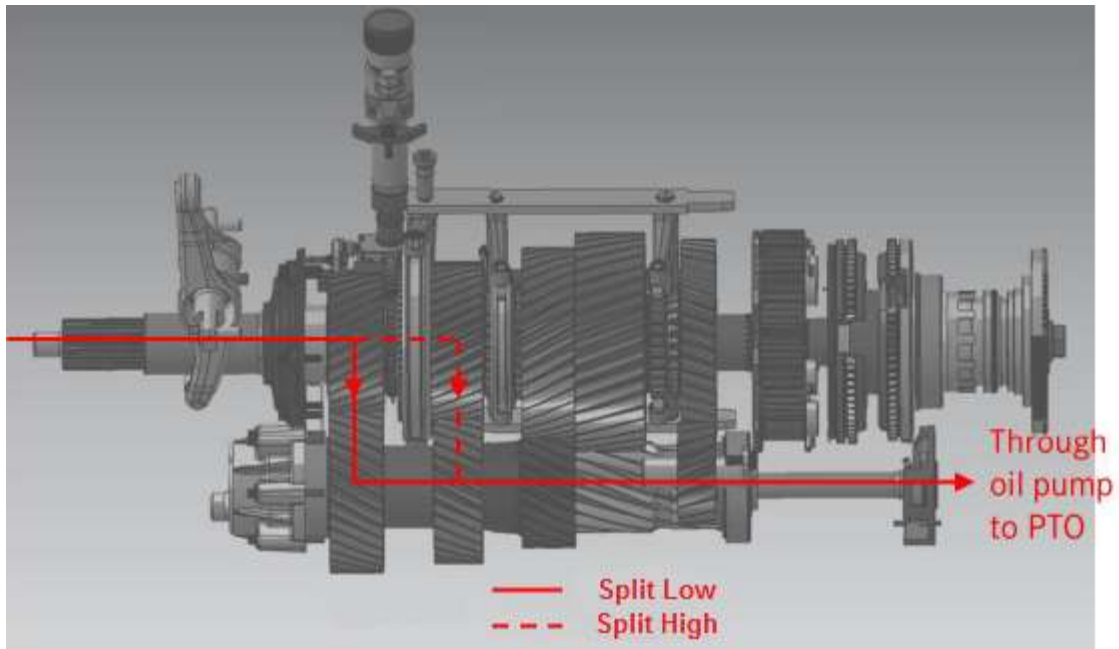

Figure 10: Example of PTO Power Flow through a Direct Drive DT12-DA (DH) or DT12-DB (DHL)

For a complete list of programming options for the DT12 Rear PTO, please see the DETROIT™ Transmissions Electronic Application and Installation Manual (DDC-SVC-MAN-0128) via the www.DTNAconnect.com website.

II. BOTTOM PTO's

Auxiliary equipment require power take-offs, either when the truck is stationary or when it is in motion. Various power take-off alternatives can be chosen, depending on the bodywork. The work is generally carried out by equipment which is powered by a hydraulic motor. The hydraulic motor, together with a pump and associated equipment, form the basis of the hydraulic system. The pump, which provides the hydraulic pressure and flow to the motor, is the heart of the hydraulic system. Below are some guidelines for Bottom PTO operation with the new DT12 variants:

- ❖ PTOs are not designed to handle axial or radial forces. No direct installation of belt pulley or sprocket on PTO output shaft is allowed.
- ❖ Due to the risk of PTO overloading, overload protection must be installed.
- ❖ Engine speed with the PTO engaged and under load must follow the instructions "Torque – Restriction (engine speed)".
- ❖ Whole number ratios are not acceptable because of risk to built-up resonance vibrations (contact PTO supplier).
- ❖ Beside the torque capacity of the PTO, its retrievable output torque (lowest torque result of the following three situations) depends on the torque reduction values for
 - shock loads (dynamic torque)
 - high bending angle of driveshaft
 - power split

The new DT12 Bottom PTO is being released to the following DT12 variants:

- DT12-DC (DHE & DV) with Chelsea PTO's only
- DT12-OC (OHE & OV) with both Chelsea & Muncie PTO's
- DT12-OD (OVX) with both Chelsea & Muncie PTO's

The following DT12 variants will only have the Rear PTO available:

- DT12-DB (DHL)
- DT12-OB (OHL)
- DT12-DA (DH)
- DT12-OA (OH)

BOTTOM PTO ROTATION DIRECTION

The direction of rotation of all Bottom PTO's (Chelsea and Muncie) is shown below:

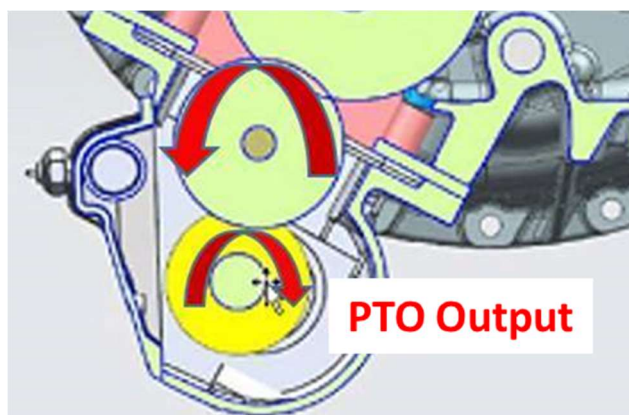

Figure 11: Bottom PTO rotation direction, as seen from the rear of the vehicle.

BOTTOM PTO OPERATION

- 1) Running Bottom PTO during normal vehicle operation.

Operation of the Bottom PTO during normal vehicle operation (while driving the vehicle with the transmission shifting gears normally) is NOT ALLOWED at this time.

NOTE: This Bottom PTO is approved for launch gear and stationary use only.

- 2) Moving of the vehicle with Bottom PTO engaged (Launch Gear Use).

NOTE: Launch gear PTO operation requires Citrine CEAA+ level software or newer. Older levels of software are NOT capable of utilizing this vehicle operation mode.

This configuration is only allowed when launching from a complete stop, utilizing the vehicle's launch gear (example: roll-off application).

To operate in this manner:

- Make sure the transmission is in neutral,
- Engage the Bottom PTO,
- Shift transmission into gear with foot on the service brake,
- Release brake to get the vehicle moving.
- To disengage the PTO, unload the PTO/system first.
- Then disengage the PTO while moving or stopped.

NOTE: The transmission may not shift gears while the vehicle is being driven with the Bottom PTO engaged. Manually shifting gears with the Bottom PTO engaged is also not allowed.

- 3) Stationary Operation:

Bottom PTO's from both Chelsea & Muncie are available for use with the DT12. See the information below which details the specifics regarding each since their limits, features, and adaptation to the transmission are different.

NOTES: Maximum output shaft speed for Chelsea Bottom PTO's is 2000rpm. (If higher rpms are needed, special approval is needed directly from Chelsea.)
Maximum output shaft speed for Muncie Bottom PTO's is 2500rpm.
Higher Bottom PTO output speeds can lead to PTO and/or vehicle equipment damage.

CHELSEA BOTTOM PTO'S

See the table below for the maximum allowed torque for permanent and intermittent operation.



Series	Chelsea			
	823	880	680*	489*
Max Torque Continuous	525 lb-ft	350 lb-ft	263 lb-ft	175 lb-ft
Max Torque Intermittent	750 lb-ft	500 lb-ft	375 lb-ft	250 lb-ft
Weight	76 lbs	37 lbs	28 lbs	30 lbs
Shift Type	Dog clutch	Dog clutch	Dog clutch	Dog clutch

Table 3: Info table on released Chelsea Bottom PTO variants

* Only compatible with hydraulic pumps with internal control valves (example: dump pumps). Approval required for other special applications.

CHELSEA MODEL NUMBER CHARTS

The Chelsea PTO model number provides a lot of information about the application where the PTO will be used. This information includes:

- PTO model number,
- Mounting type / transmission for which the PTO is designed,
- Gear ratio of the PTO as a percentage of engine speed (percentages > 100% indicate a PTO speed faster than the engine speed, while percentages < 100% indicate a PTO speed slower than the engine speed),
- Input gear designator for which the PTO is designed,
- Pressure lubrication status,
- Shifter type,
- Output designation (bolt pump mount, flange type, din spec).

Following are the model charts for the Chelsea 823 PTO for the various DT12 variants.

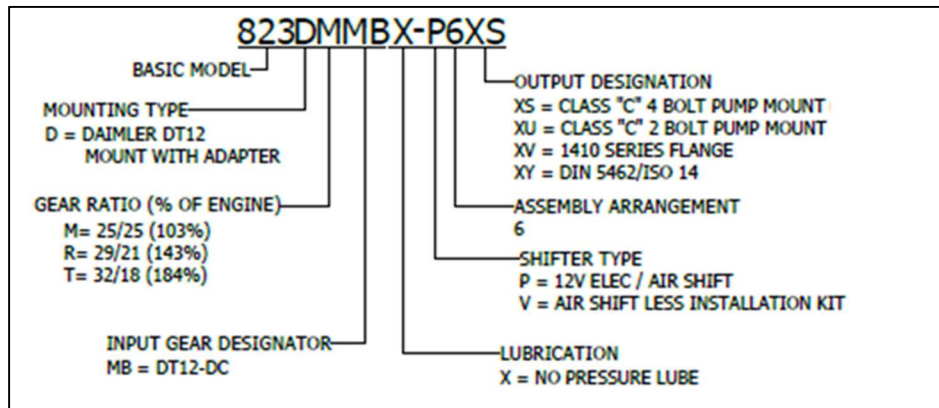

Figure 11: Model Chart for the Chelsea 823 PTO and the DT12-DC (DHE & DV).

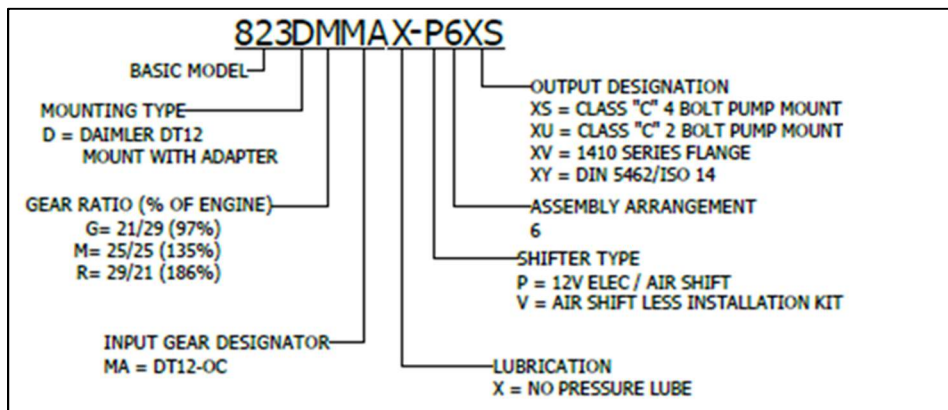

Figure 12: Model Chart for the Chelsea 823 PTO and the DT12-OC (OHE & OV).

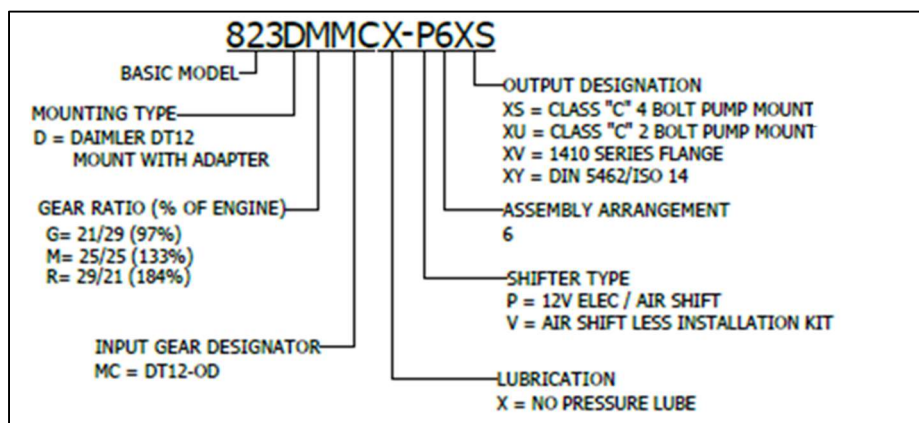

Figure 13: Model Chart for the Chelsea 823 PTO and the DT12-OD (OVX).

Below are the model charts for the Chelsea 880 PTO for the various DT12 variants.

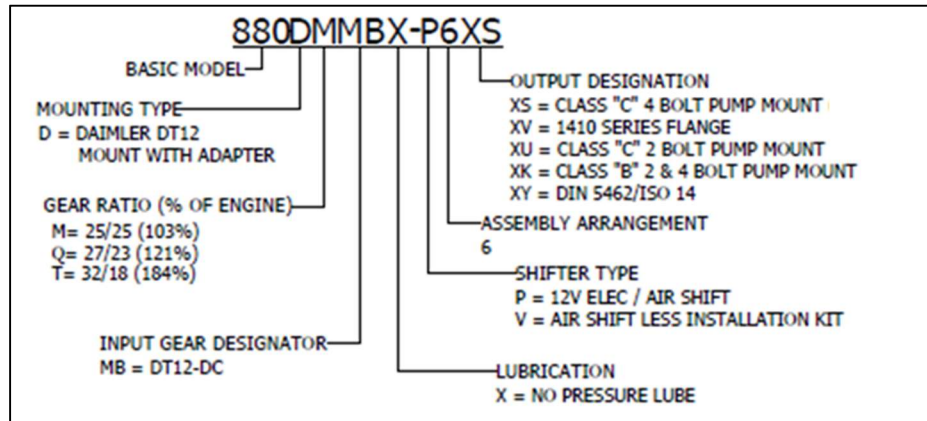

Figure 14: Model Chart for the Chelsea 880 PTO and the DT12-DC (DHE & DV).

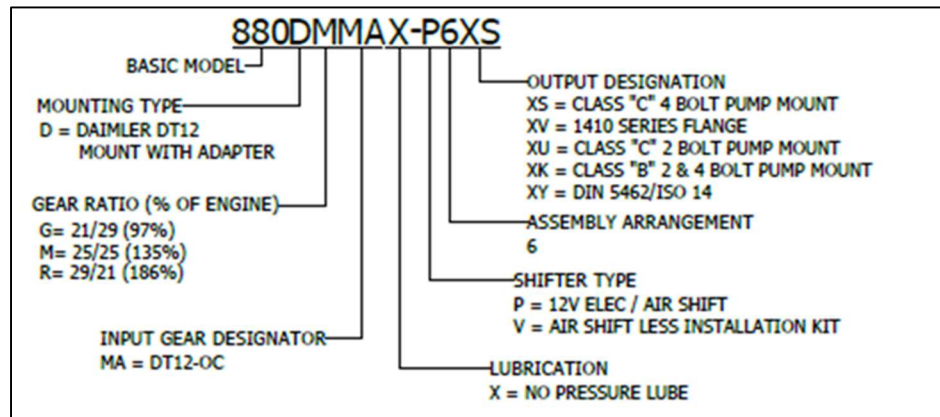

Figure 15: Model Chart for the Chelsea 880 PTO and the DT12-OC (OHE & OV).

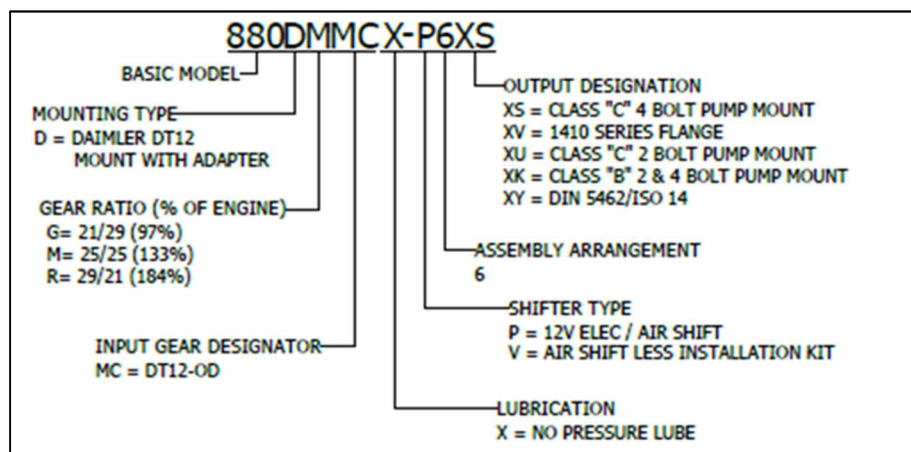

Figure 16: Model Chart for the Chelsea 880 PTO and the DT12-OD (OVX).

Below are the model charts for the Chelsea 680 PTO for the various DT12 variants.

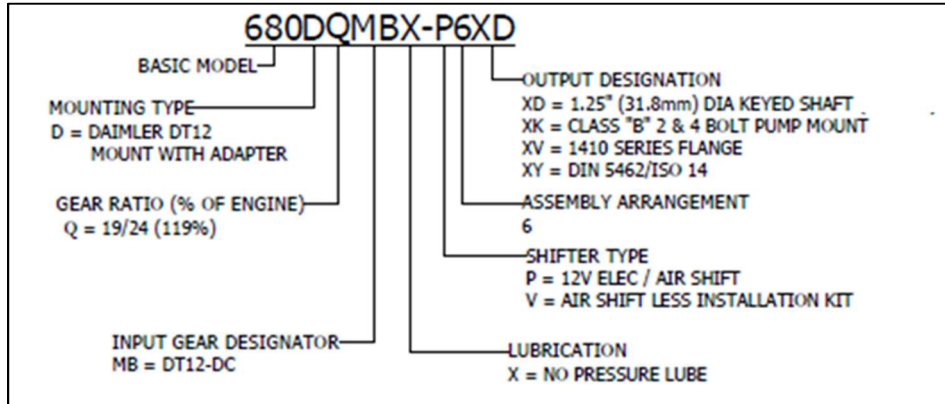

Figure 17: Model Chart for the Chelsea 680 PTO and the DT12-DC (DHE & DV)

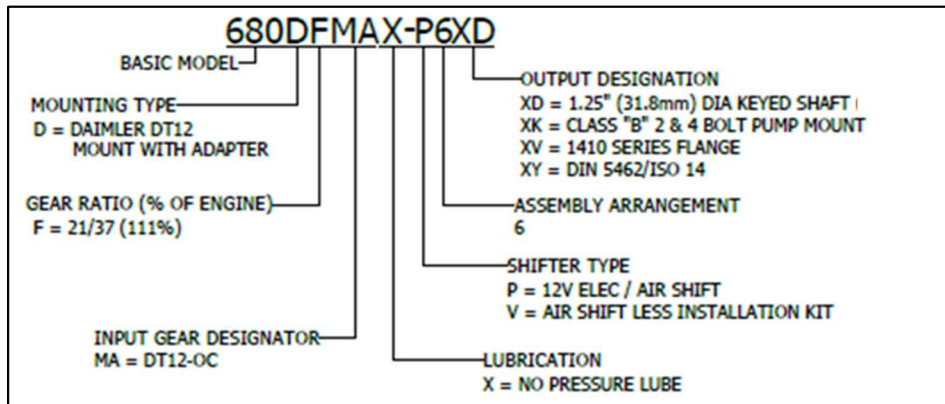

Figure 18: Model Chart for the Chelsea 680 PTO and the DT12-OC (OHE & OV).

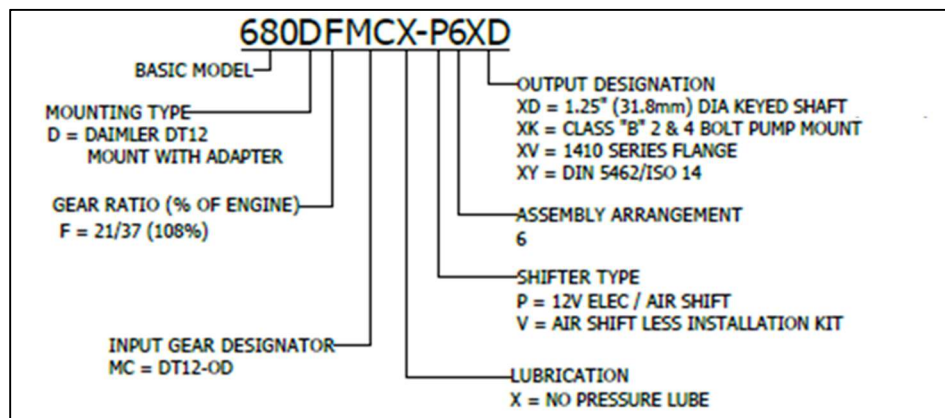

Figure 19: Model Chart for the Chelsea 680 PTO and the DT12-OD (OVX).

Below are the model charts for the Chelsea 489 PTO for the various DT12 variants.

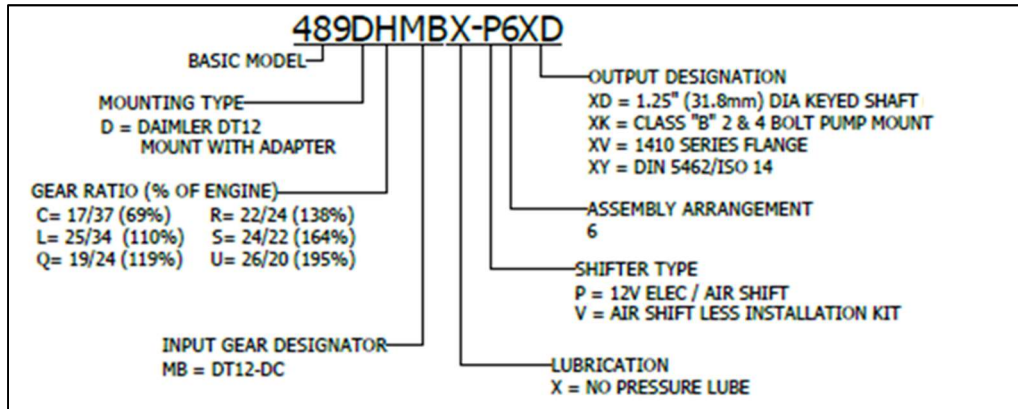

Figure 20: Model Chart for the Chelsea 489 PTO and the DT12-DC (DHE & DV).

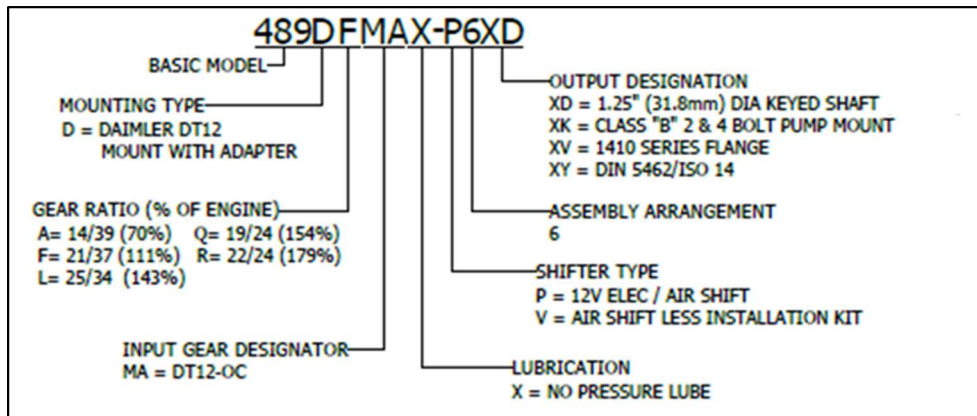

Figure 21: Model Chart for the Chelsea 489 PTO and the DT12-OC (OHE & OV).

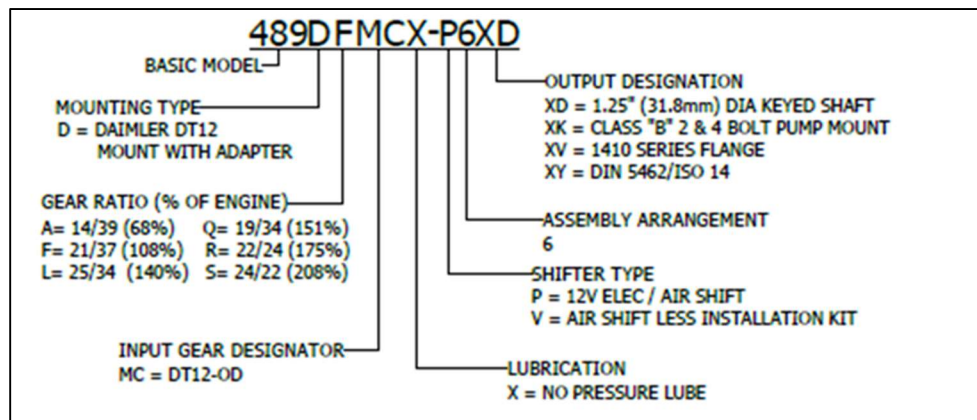

Figure 22: Model Chart for the Chelsea 489 PTO and the DT12-OD (OVX).

CHELSEA BOTTOM PTO ASSEMBLY & INSTALLATION

1. PTO Adapter Selection

The Chelsea Bottom PTO needs a separate adapter to mate the Bottom PTO to the transmission input shaft. This adapter is different for each of the transmission variants; there is also one for low power and another for high power Bottom PTO's. Below is a summary of the Bottom PTO adapters.

PTO Adapter Chart

PTO Output	Transmission	PTO Type	Adaptor Assy p/n
Low Power	DC (DHE & DV)	489	329954X
Low Power	OC (OHE & OV)	489	329932X
Low Power	OD (OVX)	489	329955X
High Power	DC (DHE & DV)	823 / 880 / 680	330033X
High Power	OC (OHE & OV)	823 / 880 / 680	330032X
High Power	OD (OVX)	823 / 880 / 680	330034X

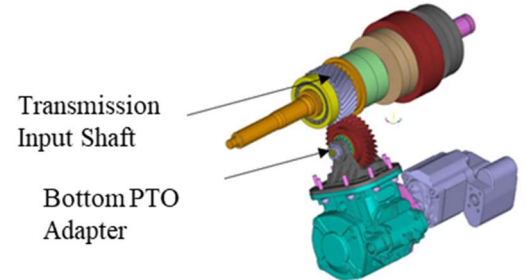

Table 4: Chelsea Bottom PTO adapter variants

The DT12 Bottom PTO hardware is available through your Chelsea PTO parts provider. The Bottom PTO adapter, which adapts the standard Chelsea PTO's approved for use to the Chelsea PTO, can be provided by your DTNA service parts representative.

NOTE: It is critical to use the correct Bottom PTO Adapter Assembly – part failure could result due to the use of the wrong adapter! The Low Power adapter must only be combined with the Low Power PTO, but the High Power Adapter can be used with both the High Power & Low Power PTO.

There are features designed/machined into the Low Power Adapter and Low Power PTO housing to ensure that the rating of the adapter is correctly matched with that of the Bottom PTO Housing as shown below.

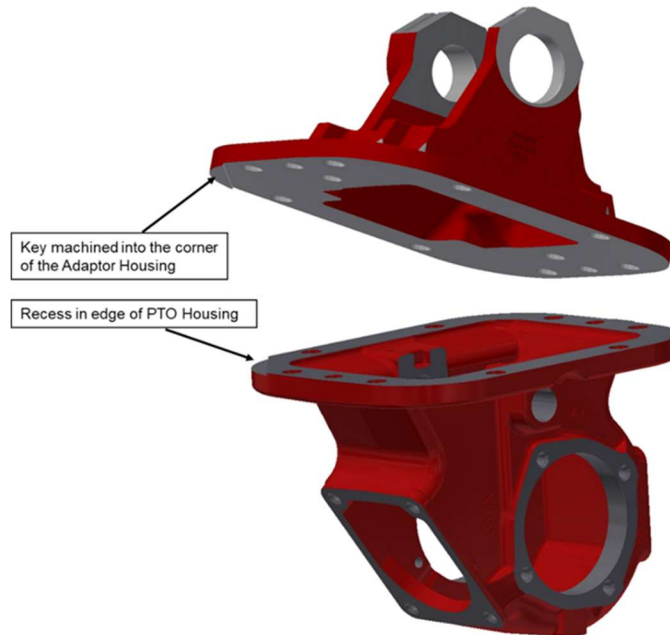

Figure 23: Low Power Bottom PTO adapter to Low Power PTO housing poka-yoke

2. Studs

Below is the detail on the studs as well as the information on how to install them for use with the DT12 Bottom PTO:

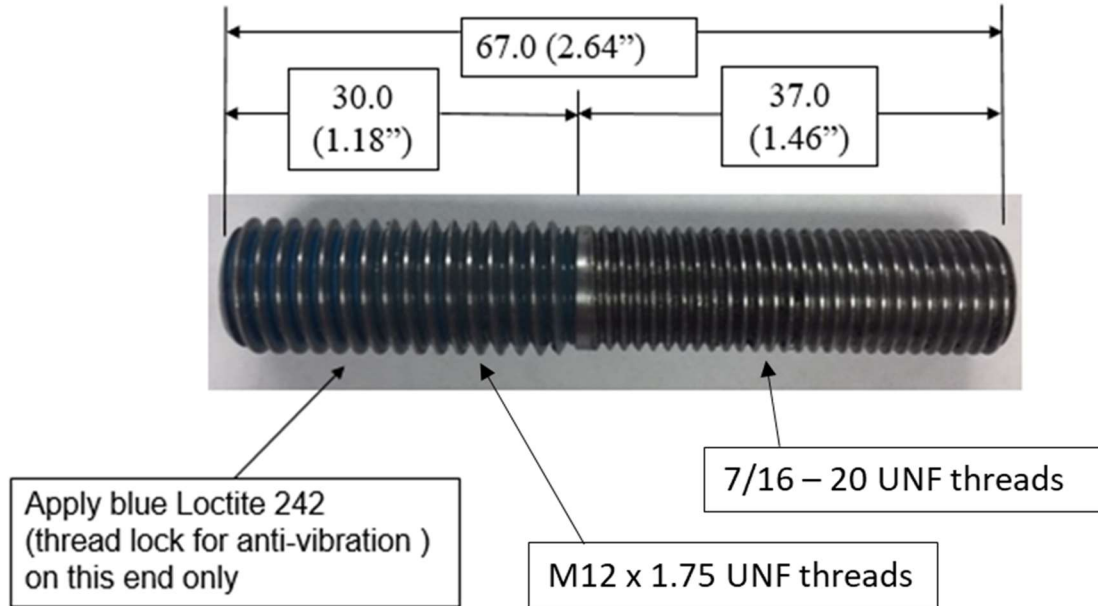

Figure 24: Stud detail information

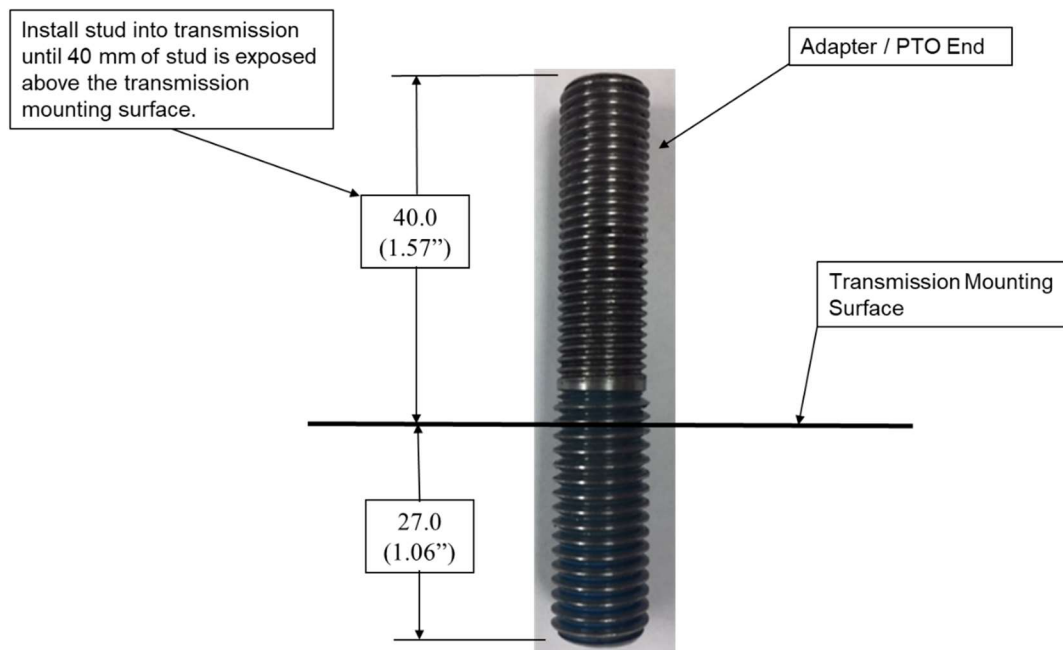

Figure 25: Stud installation information

3. Dowel Pins

Below is the detail on the dowel pins as well as the information on how to install them for use with the DT12 Bottom PTO:

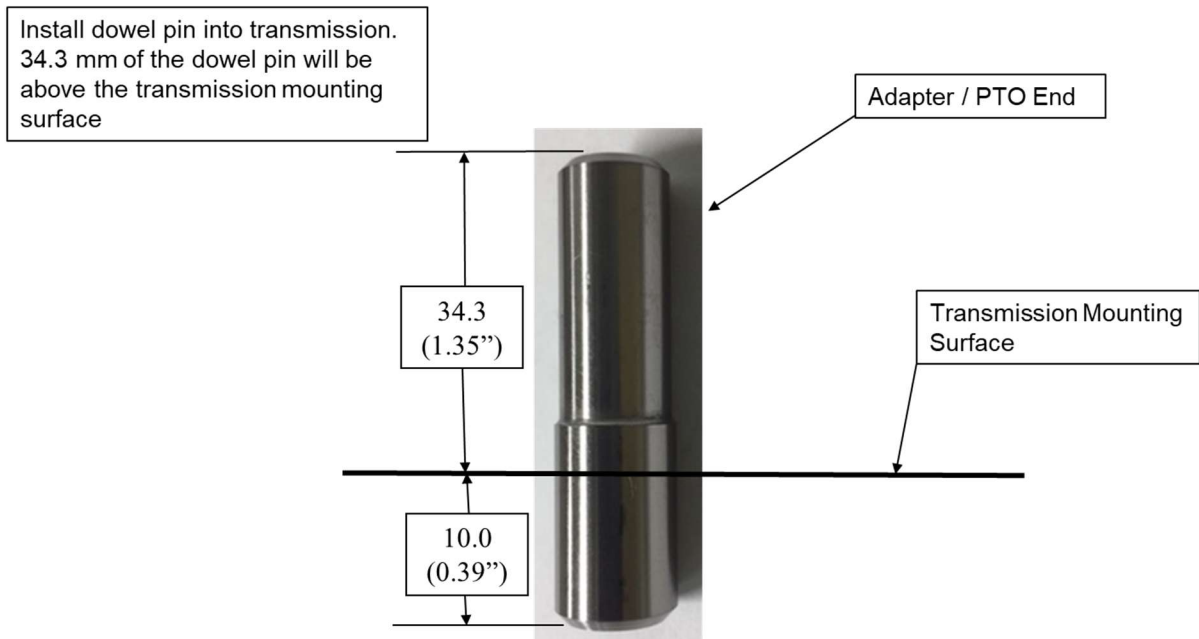

Figure 26: Stud installation information

Install the studs and dowel pins into the Bottom PTO interface of the DT12 transmission per the diagram below:

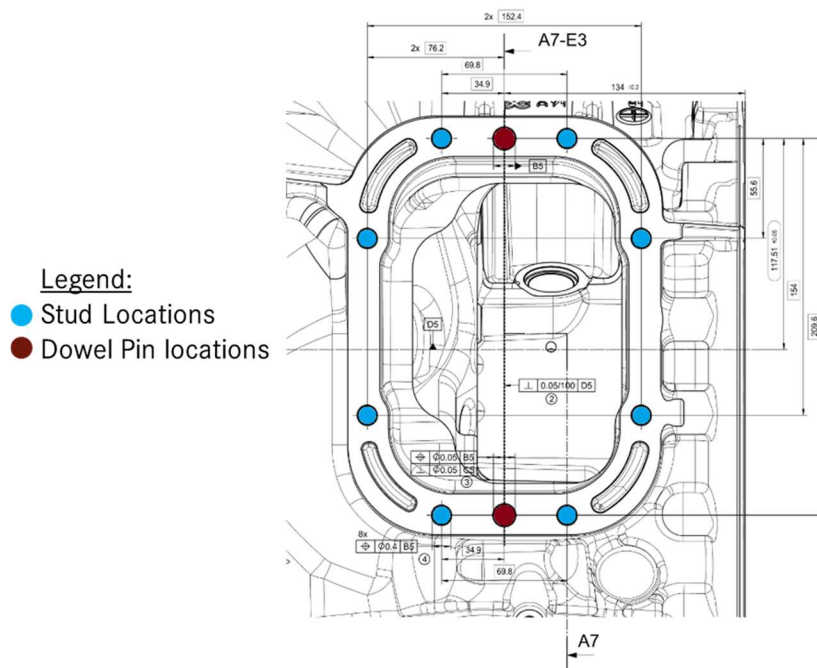

Figure 27: Stud and dowel pin installation locations

4. Adapter to PTO Installation & Backlash Adjustment

Use the below procedure to properly mate the PTO Adapter to the PTO and adjust the backlash.

- On a workbench, insert qty=1 thick gasket onto either the PTO Adapter or PTO Housing.
- Mate the PTO Adapter to the PTO Housing with qty=8 M12 (0.438") hex head bolts and nuts. Torque the bolts to 54-61 Nm (40-45 lb-ft).
- With a dial indicator, measure the backlash between the PTO gear and the adapter gear.
- Acceptable backlash measurement is 0.15-0.30 mm (.006"-.012"). See page 9 of PTO Owner's Manual.
 - If backlash is less than 0.15 mm then repeat assembly and add a thin gasket.
 - If the backlash is more than 0.30 mm then replace the thick gasket with a thin gasket.

NOTE: The maximum number of gaskets allowed between the PTO housing and Adapter is 2.

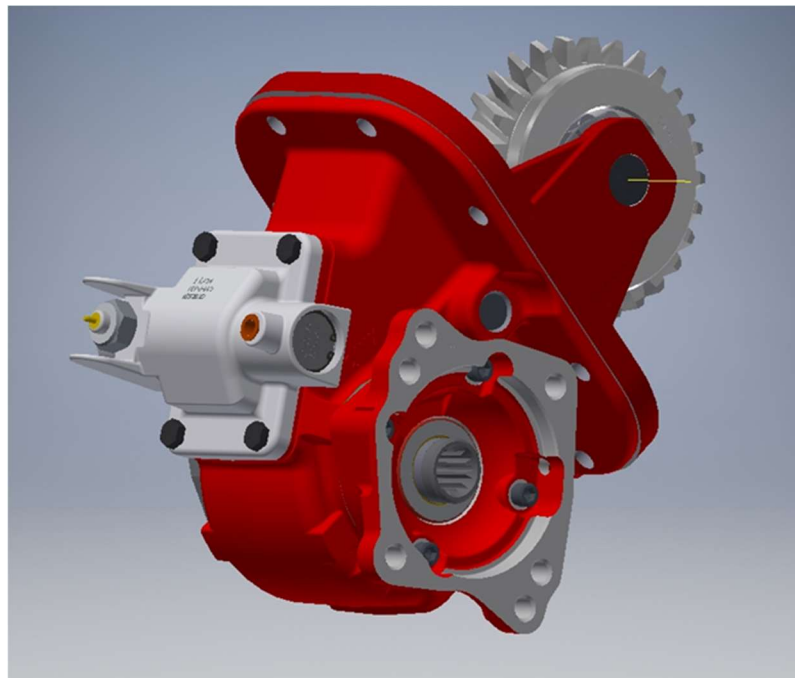

Figure 28: Measuring the Chelsea Bottom Adapter to PTO Backlash

- Disassemble the adapter from the PTO.
- Retain the gaskets used to achieve the proper backlash measurement.

5. Gasket & PTO Adapter Installation

Use the below procedure to properly install the DT12 Bottom PTO Adapter Gasket between the transmission and the Bottom PTO adapter.

- Beginning with 1 thin gasket, install the adapter gasket over the studs and dowel pins. Ensure the offset is towards the rear of the transmission.

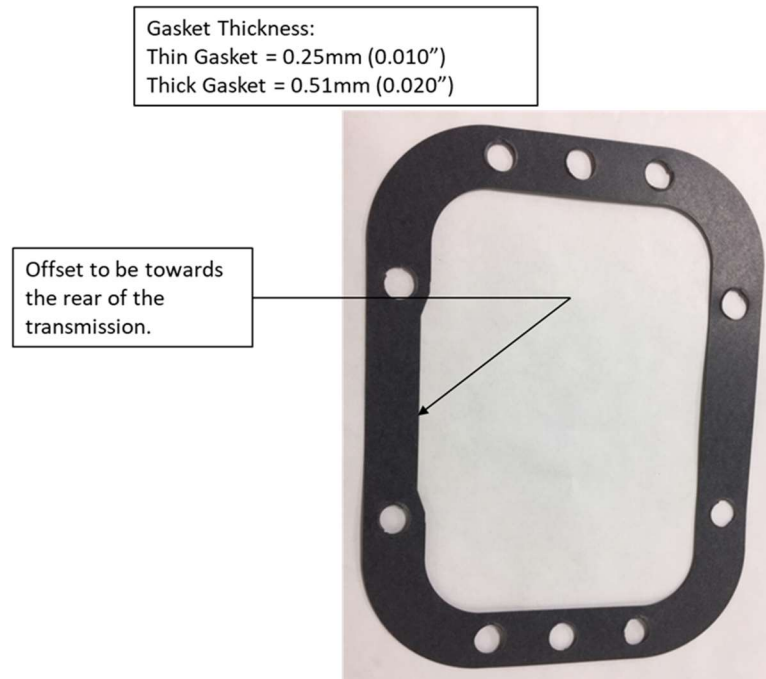

Figure 29: Bottom PTO adapter/transmission gasket installation

- Position PTO Adapter so that the ribs are towards the front of the transmission.

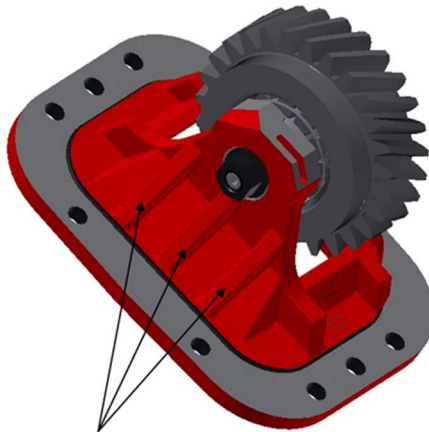

Figure 30: Mounting Bottom PTO adapter onto transmission for backlash measurement

-
- Install PTO Adapter over studs and dowel pins. Rotate the adapter gear to mesh with the transmission K1 gear.
 - Install locking nuts with washers, and torque to 40-45 Nm (30-33 lb-ft) to secure the adapter in place.
 - With dial indicator, measure the backlash between the adapter gear and the transmission K1 gear. Acceptable backlash measurement is 0.15 - 0.30mm (0.006" – 0.012").
 - If backlash is < 0.15mm (0.006"), repeat assembly with a thick gasket.
 - Once backlash is within spec, install the gaskets you set aside when you were setting the correct lash between the adapter and the PTO in section 4 above.
 - Reinstall the PTO over studs and onto the adapter with the re-installed gasket(s) from previously.
 - Temporarily secure the PTO with 2-3 locking nuts.
 - While rotating the input gear of the PTO, move the PTO further into place until the PTO gear meshes with the adapter gear.
 - Install the remaining locking nuts and torque all nuts to 75 - 81 Nm (55 – 60 lb-ft).
 - Continue PTO installation per the instructions on page 9 of the Chelsea PTO Owners Manual.

MUNCIE BOTTOM PTO'S

See the table below for the maximum allowed torque for permanent and intermittent operation.



Series	Muncie	
	TG 8S	82 8S
Max Torque Continuous	200 lb-ft	350 lb-ft
Max Torque Intermittent	285 lb-ft	500 lb-ft
Theoretic Speed ratio (engine to PTO out)	53% - 253%	57% - 95%
Weight	22 lb	85 lb
Shift Concept	Dog clutch	Dog clutch

Table 5: Info table on released Muncie Bottom PTO variants

The Muncie PTO model number provides a lot of information about the PTO and how it is configured in the application. This information includes:

- PTO type,
- Mounting type / transmission for which the PTO is designed,
- Speed ratio of the PTO as a percentage of engine speed (Percentages > 100% indicate a PTO speed faster than the engine speed, while percentages < 100% indicate a PTO speed slower than the engine speed),
- Shifter type,
- Assembly arrangement,
- Output types,
- Special features.

Please consult the Muncie documentation for the TG and 82 Series Power Take-Off's for additional information on PTO torque & horsepower ratings at the different speed ratios, PTO dimensions, and output options.

NOTES: Maximum output shaft speed for Muncie Bottom PTO's is 2500rpm.
Higher PTO output speeds can lead to PTO and/or vehicle equipment damage.

Muncie Bottom PTO's are only available on the following DT12 variants only:

- DT12-OC (OHE & OV)
- DT12-OD (OVX)

Below are the model number charts for the Muncie Bottom PTO's for the DT12 variants.

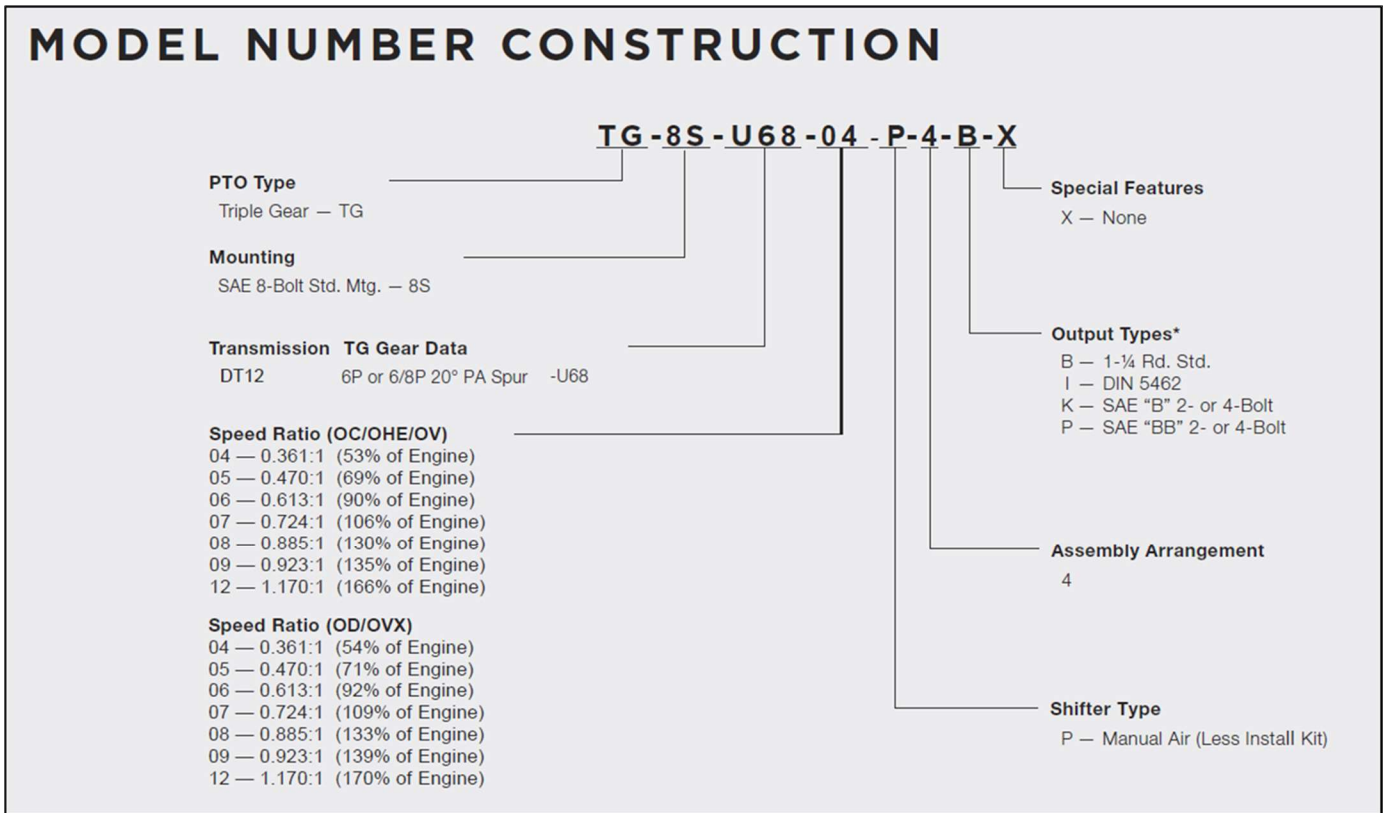

Figure 31: Model Chart for the Muncie TG 8S Bottom PTO

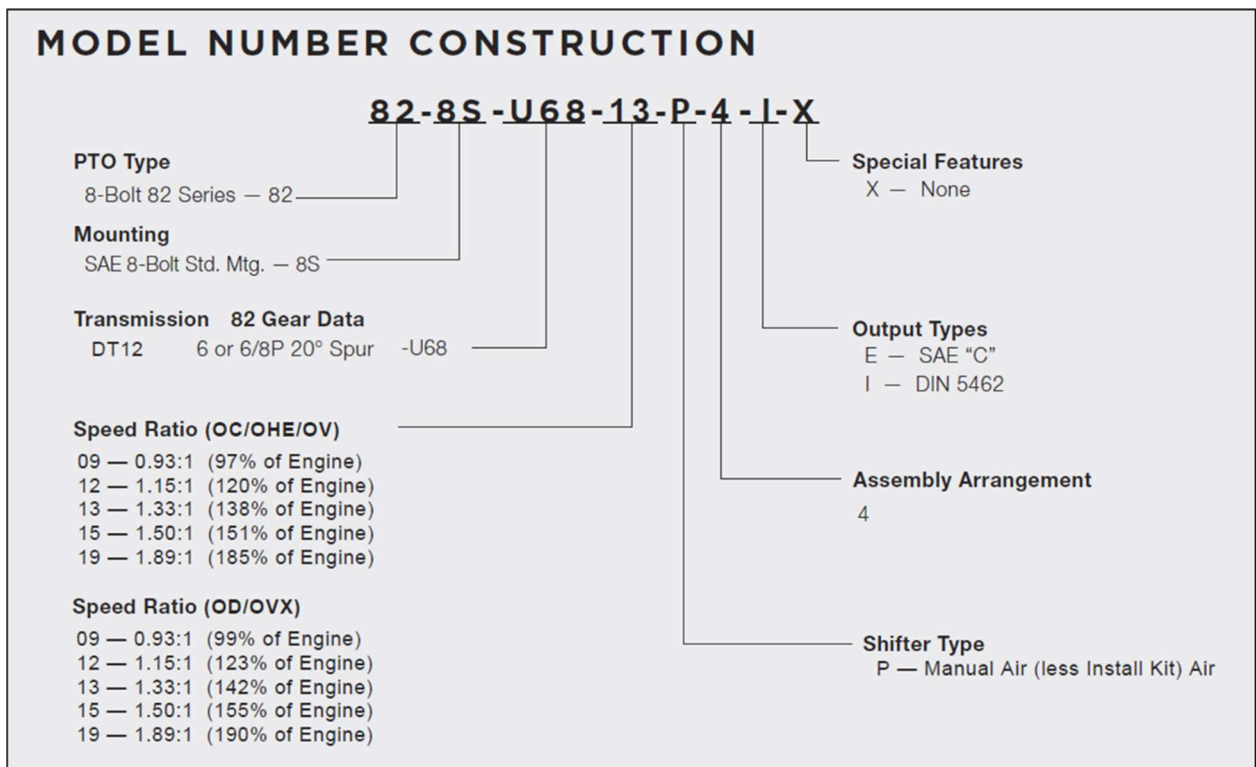

Figure 32: Model Chart for the Muncie 82 8S Bottom PTO

MUNCIE BOTTOM PTO ASSEMBLY & INSTALLATION

1. PTO Adapter Selection

The Muncie Bottom PTO needs a separate adapter to mate the PTO to the transmission input shaft. This adapter is different for the different transmission variants. Below is a summary of the Muncie Bottom PTO adapters.

Transmission	Adapter	Adapter Gear P/N
DC (DHE & DV)	No option available	N/A
OC (OHE & OV)	40TA6479	05T64697
OD (OVX)	40TA6480	05T64698

Table 6: Muncie Bottom PTO adapter variants

The DT12 Bottom PTO hardware and Installation Kits are available through your Muncie Power parts provider.

2. Adapter to Transmission Installation

Use the below procedure to properly mate the PTO Adapter to the DT12 transmission.

- Drain the transmission fluid from the transmission by removing the drain plug. Measure the amount of fluid removed if it will not be re-used.
- Remove the PTO cover plate and gasket from the Bottom PTO opening on the transmission. You will NOT be re-using these components.
- Locate the 2 alignment pins/dowels in the installation kit, and install the pins at the 6 and 12 o'clock positions in the adapter.

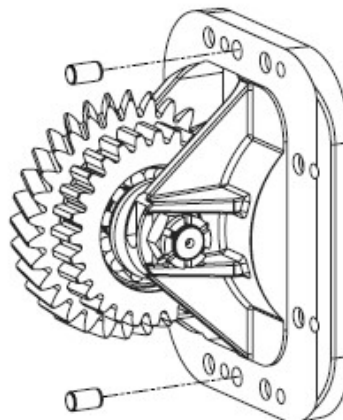

Figure 33: Installation of the dowel pins into the Muncie Bottom PTO Adapter

- Apply a thin coating of approved transmission oil on both sides of the gasket to be installed between the transmission and the PTO adapter – this will help hold it in place during the installation process.
- Install the adapter on the transmission using the thicker gasket (0.020") included with the installation kit, and torque the qty=8 M12x30 cap screws to 50 lb-ft (68 N-m).

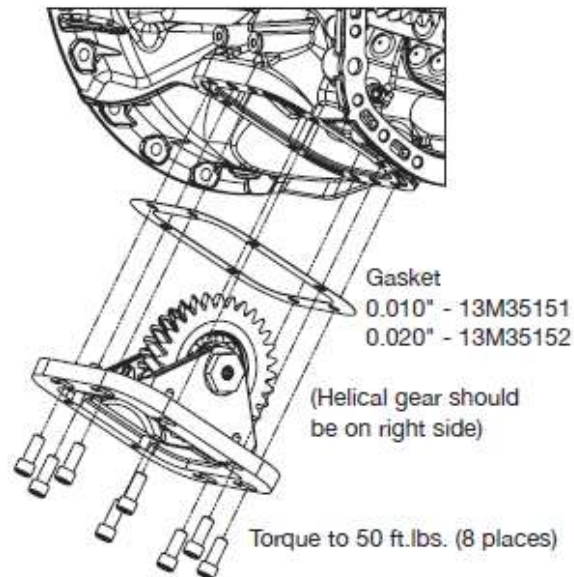
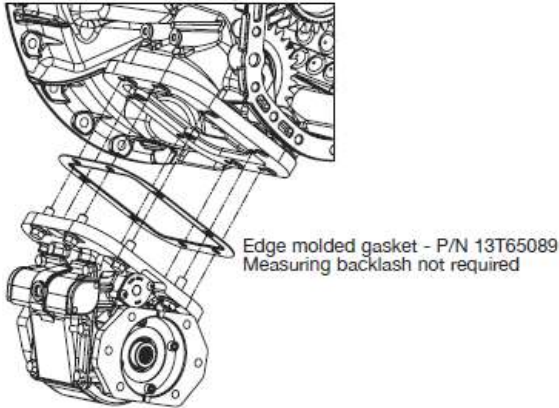

Figure 34: Installation of the Muncie Bottom PTO Adapter to the transmission

- Measure the backlash between the adapter and transmission gears. Correct backlash should be 0.006"-0.012" (0.15mm – 0.30mm). Adjust as necessary using a second gasket. A thinner gasket, one that measures 0.010" (0.25mm) thick, is available and is shown in Figure 35 above. Additional gaskets are available through your Muncie Power parts provider.
- Now prep the PTO for installation onto the PTO adapter.
 - For the TG Series PTO's, use stud kit 20MK8801 which includes 6 cap screws, 2 studs & nuts, and 8 lock washers. Lock washers should be used on each fasteners (8 places).
 - For the 82 Series PTO's (not the 15 and 19 ratios), use stud kit 20MK8815 which includes 8 studs & nuts along with 8 lock washers.
 - For the 82 Series PTO's (with the 15 or 19 ratio), use stud kit 20MK8817, which is similar to the 20MK8815 above, but includes longer studs to accommodate the required spacer.
- Install the PTO onto the adapter.
 - Use the edge molded gasket between the adapter and the PTO, or between the adapter and any spacer plates required for PTO installation.
 - Backlash measurement is not required between the PTO and adapter if no spacers are used between these two components during installation. If a shim is used, the gear backlash between PTO and adapter gears specification is 0.006" -0.012" (0.15mm – 0.30mm).
 - Torque the cap screws (TG Series) or nuts (82 Series) to 50 lb-ft (68 N-m)

NOTE: It is critical that the edge-molded gasket is used against the PTO Adapter – failure to do so may result in oil leakage!

TG Series, 82 Series 05 - 13 ratios
 Setting backlash between PTO and adapter NOT required



82 Series 15 and 19 ratios only
 Backlash must be set between PTO and adapter!

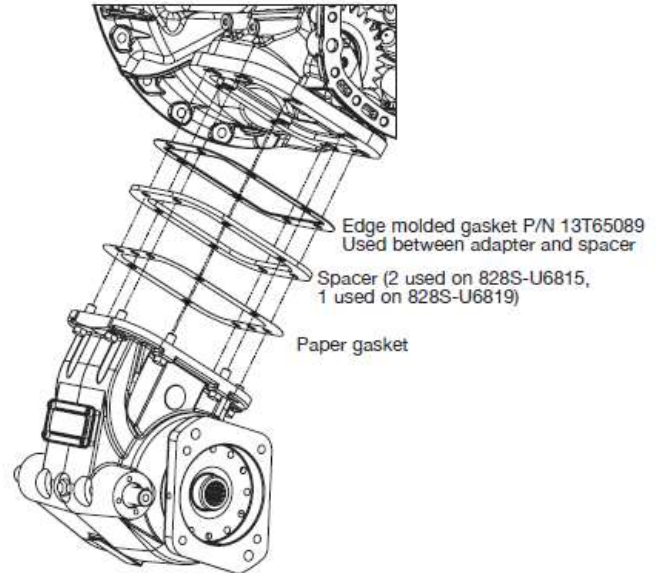

Figure 35: Installation of the Muncie PTO to the PTO Adapter and transmission

NOTE: See Muncie PTO Operators Manual, IN84-03, for further PTO Installation details, activation kit instructions, as well as warranty and maintenance information.

PTO POWER SPLIT

The term PTO Power Split refers to the simultaneous operation of the Rear and Bottom PTO's. While operating at the same time, the maximum torque load distribution among the PTO's has to meet the following boundary conditions:

- Max Continuous Torque = 525 lb-ft
- Max Intermittent Torque = 750 lb-ft

The definition of "Intermittent Torque" is as follows:

Maximum torque for 1.5 minutes in a 15-minute cycle.

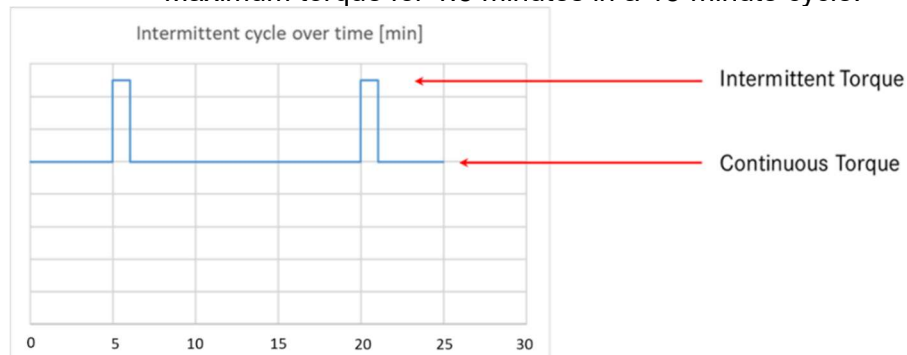

Figure 36: Torque signal showing intermittent vs Continuous Torque

BOTTOM MOUNTED PTO SUPPORT REQUIREMENTS

A Bottom PTO support bracket must be used if either of the two conditions below are met:

1. The combined weight of the pump, fittings and hoses exceeds 40 lbs (18.1 kg)
2. The combined length of the PTO and pump is 18 inches or more from the PTO centerline to the end of the pump.

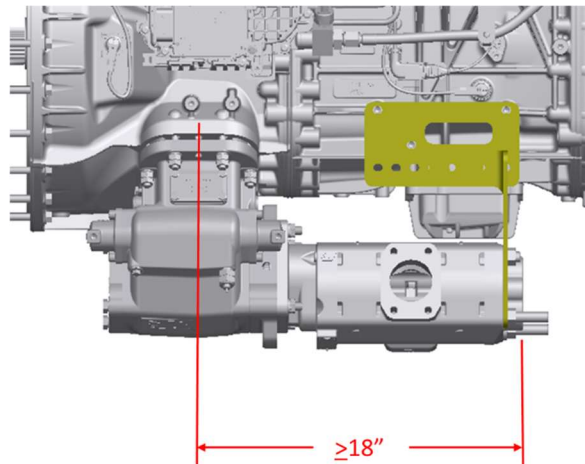

Figure 37: Combined Length Requirement for Bottom PTO Support Bracket

NOTE: The bracket must be installed without the weight of the installed pump to avoid additional stresses on the PTO mounting and the transmission-Bottom PTO interface.

Hydraulic Hoses

To reduce the impact of hose weight on the PTO assembly, bracket(s) **MUST** be installed to support the hoses. The minimum distance between pump fitting and the first bracket is approximately 2 ft (~600mm). Brackets installed too close to the hydraulic pump might cause additional stresses.

Also, you **MUST** use supporting brackets for the connections to the hydraulic oil, etc. once it is routed away from the pump or PTO connection as described above.

NOTE: The support bracket mentioned will be available through DTNA in the future. Additional information will be provided in a future update.

Below is an example support bracket for mounting the Bottom PTO on the DT12 transmission mid-housing.

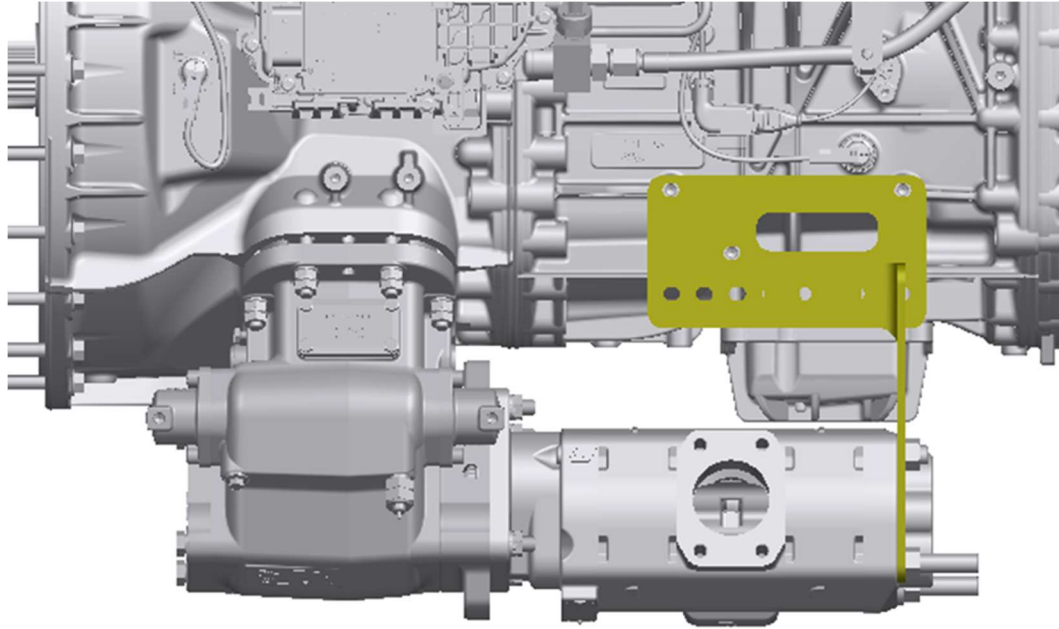
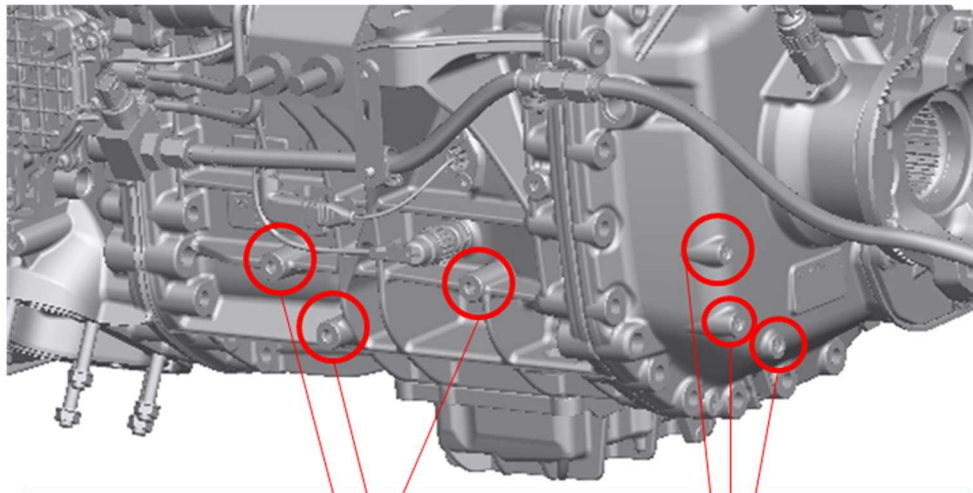

Figure 38: Example DT12 Bottom PTO support bracket



Support brackets can be mounted to the mid housing OR the rear housing, but not a combination of both locations.

Figure 39: Bottom PTO support bracket mounting boss locations

The required size and thread pitch for the Bottom PTO support bracket bolts is M10 x 25. The thread depth in the hole in the block is 25mm, the drilled depth is 30mm.

Below are the dimensions on the DT12 mid-housing if a support bracket is required. The available mounting hole locations are highlighted in red for clarity

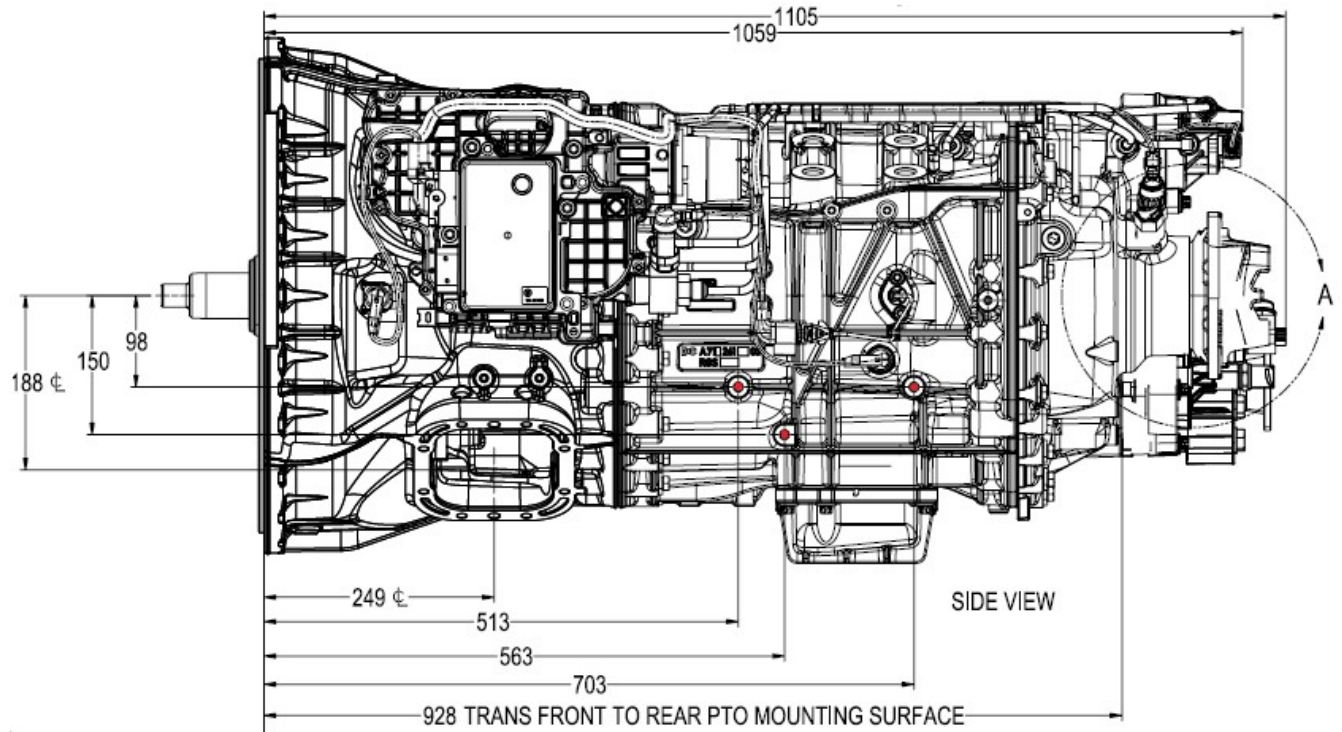

Figure 40: Mid-housing dimensions (in mm) for Bottom PTO Support Bracket

Below are the dimensions on the DT12 rear housing if a support bracket is required. The available mounting hole locations are highlighted in red for clarity

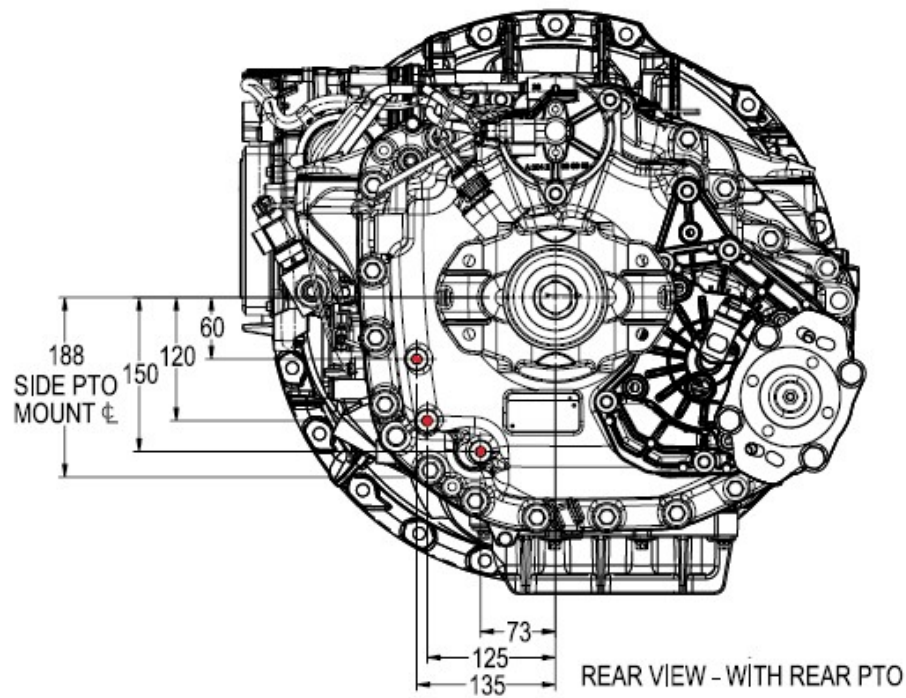

Figure 41: Rear-housing dimensions (in mm) for Bottom PTO Support Bracket

Here are some examples of actual Bottom PTO support brackets:

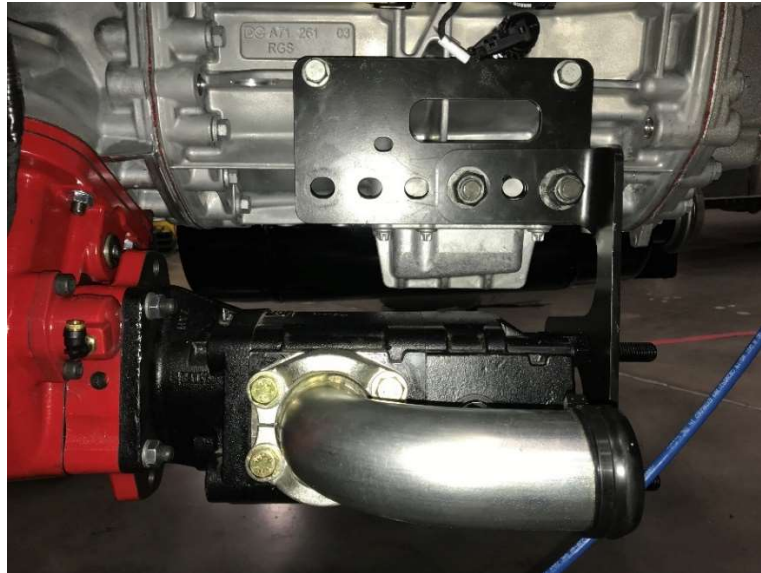

Figure 42: Actual Bottom PTO support bracket, pic 1



Figure 43: Actual Bottom PTO support bracket, pic 2

The mating piece to the 90 degree connection off of the Bottom PTO pump shown in the above pictures must also be supported.

RESONANCE FREQUENCIES & PTO OPERATION SPEEDS

Beside the torsional excitation of the system by engine combustion or driveshafts the resonance frequency of the system is also a major concern. To avoid critical operation conditions and/or damages of powertrain components the pto operation rpm has to stay away from natural frequencies. The recommended PTO Torque by engine speed is shown in the graph below.



Figure 44: Recommended Bottom PTO Torque by engine speed and PTO type

To avoid uncomfortable resonances and noises in high torque applications, it is recommended to operate the PTO above 900 rpm engine speed.

In addition to the maximum PTO output torque recommendations shown above, proper PTO setup must also keep PTO output speeds below maximum limit by the PTO Manufacturer.

NOTES: Maximum output shaft speed for Chelsea Bottom PTO's is 2000rpm. (If higher rpms are needed, special approval is needed directly from Chelsea.
Maximum output shaft speed for a Muncie Bottom PTO is 2500rpm.

PTO DRIVESHAFT INSTALLATION

Maximum torque can only be applied if the operation is completely oscillation and shock free. To keep the excitation as low as possible, the following requirements must be met.

- Bending angles $\alpha_1 = \alpha_2 / \Delta\alpha \leq \pm 1^\circ$
- Both driveshaft joint in one plane



- Drive shaft installation; either Z - or W - pattern

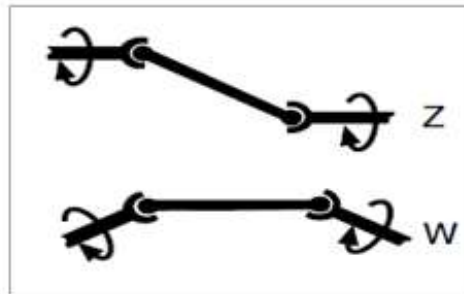

Figure 45: Driveshaft installation angle requirements

In the case of three dimensional driveshaft installation, when the lines of the input and output shafts are crossing each other with an offset (combined cases of Z = and W – pattern), the following conditions must be met to avoid additional excitation.

- Bending angles $\beta_1 = \beta_2 / \Delta\beta \leq \pm 1^\circ$
- The inner driveshaft joint forks have to be twisted until they in the planes A and B.

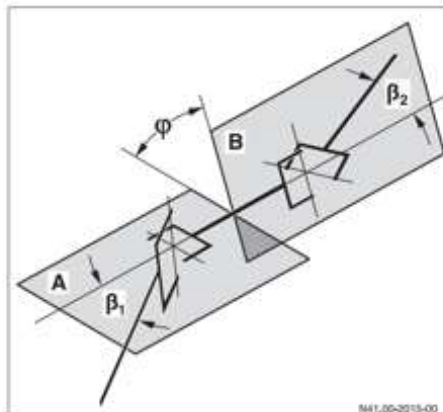

Figure 46: Driveshaft installation angle requirements when in 2 planes

In either of the above driveshaft angle configurations, if a driveshaft bend angle $> 6^\circ$ is not avoidable, follow the instructions below for large Joint Bend Angles.

JOINT BEND ANGLES

In addition to the driveshaft installation pattern, the joint bend angle significantly effects the driveshaft acceleration and additional dynamic torque load. The minimum bend angle requirement is shown below.

A minimum bending angle of 1° is required.

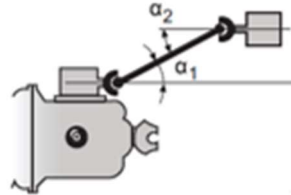

Figure 47: Minimum bend angle requirement

When bending angles $> 6^\circ$ the maximum PTO torque load must be reduced per the figure below.

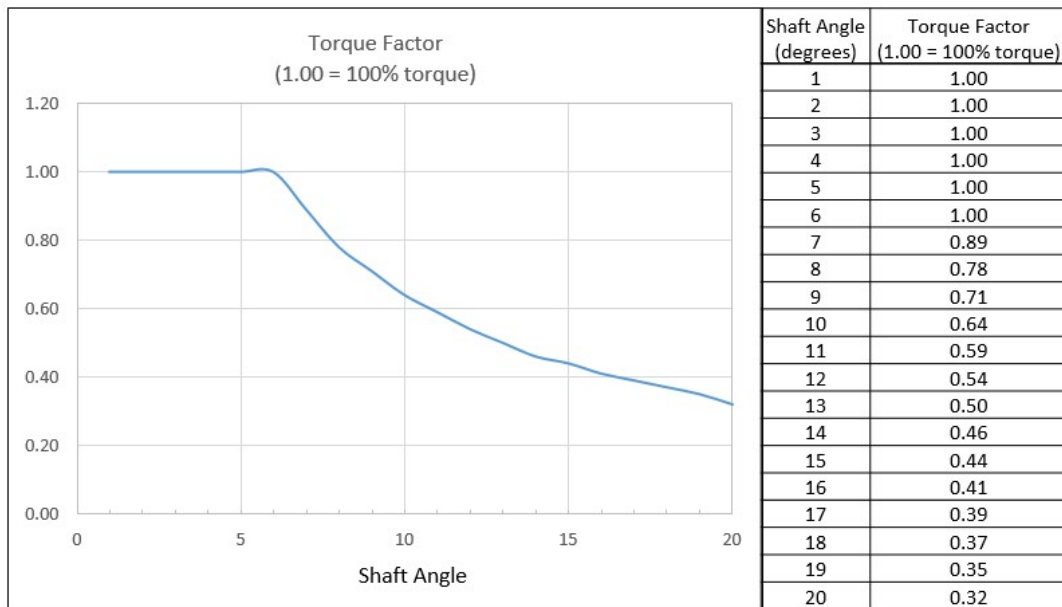

Figure 48: Torque Reduction when bend angles > 6 degrees.

SHOCK LOAD (DYNAMIC TORQUE)

Maximum torque can only be applied if the operation is completely oscillation and shock free. The dynamic torque or shock load varies by application, but the system has to be dimensioned and set-up to handle the highest combination of static plus dynamic torque.

The following overview is only an example, please verify the specifics of your application meet the appropriate dynamic factor.

The Operation Torque plus the shock overload **MUST** be less than the PTO torque limit.

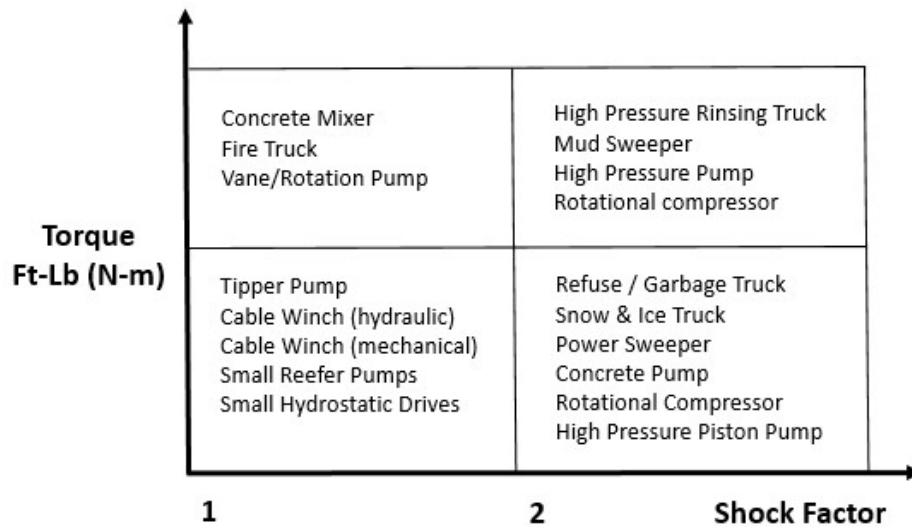

Figure 49: PTO Shock Load Factor

Engineering Change Log

Technical Content / Publisher Owner	Rev. #	Rev. Date	Description of Revisions
C. Grissom	R01	12OCT16	Initial release.
C.Grissom	R02	27OCT16	Added notes to PTO configurations 1 & 2. Added Figure 5 showing option #2 installed in truck. Updated torque values on Spicer flange kit installation. Modified torque values to show English units first. Clarified verbiage for Table 1.
C.Grissom	R03	07DEC16	Updated footer, and added note regarding CPC parameterization for each configuration offered.
C.Grissom	R04	19DEC16	Corrected PTO rotation direction on page 7.
C.Grissom	R05	23JAN17	Corrected PTO drive shaft angular requirement on page 6; clarified split low/high verbiage on page 9.
C.Grissom	R06	08APR17	Modified document name, revised Technical Information on page 7 including rotation direction, added Table 2 on page 9.
C.Grissom	R07	03MAY17	Updated/inserted/labeled Figure 9 on page 7.
C.Grissom	R08	19MAY17	Added note to page 7 regarding pump input direction
C.Grissom	R09	25OCT17	Updated Figures 9 & 10.
C.Grissom	R10	16APR18	Inserted 2 new PTO configurations (#3 & #4) and corresponding configuration information, then renumbered existing configurations to #5 & #6; Removed previous Table 1, inserted new Table 1, inserted and modified verbiage in PTO output speed calculation section.
C.Grissom	R11	10JUL20	Added part numbers for the Rear PTO prep kits, clarified examples on how to calculate PTO speed after Table 2, added entire Side PTO section for new option on Transmission 2020 releases.
C.Grissom	R12	31MAR21	Changed all Side PTO verbiage to Bottom PTO verbiage. Updated ratios in Table 2. Added Muncie Bottom PTO information.